

EUROPEAN ORGANISATION  
FOR THE SAFETY OF AIR NAVIGATION



EUROCONTROL EXPERIMENTAL CENTRE

**3rd CONTINENTAL RVSM  
REAL-TIME SIMULATION**

**EEC REPORT No. 315**

EEC Task : **S08**  
EATCHIP Task : NAV 2

Issued: July 1997



**REPORT DOCUMENTATION PAGE**

<b>Reference:</b> EEC Report No. 315		<b>Security Classification:</b> Unclassified				
<b>Originator:</b> EEC - RTO (Real-Time Simulations Operations)		<b>Originator (Corporate Author) Name/Location:</b> EUROCONTROL Experimental Centre B.P.15 F - 91222 Brétigny-sur-Orge CEDEX FRANCE Telephone : +33 (0)1 69 88 75 00				
<b>Sponsor:</b> EUROCONTROL HQ DED.4 (ANT)		<b>Sponsor (Contract Authority) Name/Location:</b> EUROCONTROL Agency Rue de la Fusée, 96 B -1130 BRUXELLES Telephone : +32 2 729 9011				
<b>TITLE:</b>  <b>3RD CONTINENTAL RVSM REAL-TIME SIMULATION</b>						
<b>Authors :</b> Roger Lane Robin Deransy Diana Seeger	<b>Date</b> 7/97	<b>Pages</b> x+69	<b>Figures</b> 29	<b>Tables</b> 9	<b>Appendix</b> 3	<b>References</b> 4
<b>EATCHIP Task Specification</b> NAV 2	<b>EEC Task No.</b> S08		<b>Task No. Sponsor</b> -		<b>Period</b> 1997	
<b>Distribution Statement:</b> (a) Controlled by: Head of RTO (b) Special Limitations: None (c) Copy to NTIS: YES						
<b>Descriptors (keywords):</b> Air Traffic Control (ATC), Reduced Vertical Separation Minima (RVSM), Conventional Vertical Separation Minima (CVSM), Flight Level Orientation Scheme (FLOS), Minimum Aircraft System Performance Specification (MASPS), Controller workload, State Aircraft.						
<b>Abstract:</b> The S08 Real Time Simulation was the third Continental Reduced Vertical Separation Minima (RVSM) Simulation to be conducted at the EUROCONTROL Experimental Centre (EEC) at Bretigny, France. The aim of the simulation was to continue to study the benefits of the Single and Double Alternate FLOS within the core area of European airspace using a multi-Air Traffic Control Centre (ATCC) environment.						

This document has been collated by mechanical means. Should there be missing pages, please report to:

EUROCONTROL Experimental Centre  
Publications Office  
B.P. 15  
91222 - BRETIGNY-SUR-ORGE CEDEX  
France



## SUMMARY

The S08 Real Time Simulation was the third Continental Reduced Vertical Separation Minima (RVSM) Simulation to be conducted at the EUROCONTROL Experimental Centre (EEC) at Bretigny, France. The first simulation studied the use of the Single Alternate Flight Level Orientation Scheme (FLOS) within French and Swiss airspace. The second simulation studied the Single and Double Alternate FLOSs within Hungarian Airspace.

The results from the first two simulations showed that the six extra flight levels available with RVSM offered many operational benefits. The aim of the third simulation was to continue to study these benefits within the core area of European airspace using a multi-Air Traffic Control Centre (ATCC) environment.

Civilian Controllers from four different ATCCs (Reims-France, Karlsruhe-Germany and Geneva and Zurich-Switzerland) and Military Controllers from Lyon CDC took part in the simulation using a common HMI with no changes to sectorisation or route network for the majority of the simulation. Three different levels of traffic sample (1996+35/+55/+65%) were used to study the effect of RVSM on the controllers' workload.

The initial intention was to study the Double Alternate FLOS as this had been the FLOS preferred by the controllers during the second continental simulation. To validate this preference, exercises using the Single and Double FLOS were run at the +35% level of traffic. After 8 days of simulation the controllers were asked their preference, 10 controllers preferred the Single FLOS, 5 preferred the Double FLOS and 5 considered it too soon to make a decision. It was therefore agreed to continue to examine the Single and Double FLOS for the remainder of the simulation.

During the simulation the controllers quickly adapted to using the RVSM levels regardless of the FLOS and everyone agreed that these levels should be introduced as soon as possible. Most of the controllers considered that either FLOS could be used within their airspace providing that ATC procedures, letters of agreement, sectorisation and route networks are reviewed and amended as necessary.

The results of the simulation show that there was no significant difference in workload between the Single and Double Alternate FLOS. There was no clear preference between the Single and Double Alternate FLOS and many of the advantages and disadvantages that apply to one FLOS can apply to the other FLOS as well, depending on the size and shape of the airspace concerned.

There was a reduction in controller workload when RVSM (without non-MASPS traffic) was compared to CVSM. However, the introduction of non-MASPS aircraft increased the controllers workload and severely reduced the benefits of RVSM. The controllers found non-MASPS traffic very difficult to integrate with MASPS traffic because it meant they were having to provide two different separation standards within the same airspace.

The simulated airspace included many congested crossover points. Although a Flight Level Allocation Scheme (FLAS) was not studied during this simulation it is recommended that future simulations examine the application and potential benefits of a FLAS which could be used regardless of the FLOS and would help to resolve many current problems faced by controllers when crossing traffic from multiple directions.



## ACKNOWLEDGEMENTS

The Project Manager would like to wish a particular thank you to the following:

- The French, German and Swiss ATC Authorities for their generous assistance in the S08 project
- The S08 Project Team ; Jose Seixo, Hugh O'Connor, Marie Christine Leduc, Robin Deransy, Diena Seeger, Françoise Roth, Martine Parvais, Laurent Guichard and Mark Stoner.
- All the simulator pilots and staff at the EEC who were involved in the project.
- All the Air Traffic Controllers of the French Civil and Military, German and Swiss Centres, who participated in the study.

Roger Lane

S08 Project Manager



## CONTENTS

<b>ANNEXES</b> .....	<b>ix</b>
<b>REFERENCES</b> .....	<b>ix</b>
<b>LIST OF ABBREVIATIONS AND ACRONYMS</b> .....	<b>x</b>
<b>1. INTRODUCTION</b> .....	<b>1</b>
<b>1.1 DEFINITION OF TERMS</b> .....	<b>1</b>
1.1.1 Conventional Vertical Separation Minima (CVSM) .....	1
1.1.2 Reduced Vertical Separation Minima (RVSM).....	1
1.1.3 Single Alternate Flight Level Orientation Scheme .....	2
1.1.4 Double Alternate Flight Level Orientation Scheme.....	2
1.1.5 MASPS and Non-MASPS .....	2
1.1.6 State and Non-State Aircraft .....	3
<b>2. RVSM BACKGROUND</b> .....	<b>4</b>
<b>3. THE S08 CONTINENTAL RVSM REAL-TIME SIMULATION</b> .....	<b>5</b>
<b>3.1 SIMULATION OBJECTIVES</b> .....	<b>5</b>
3.1.1 General objectives .....	5
3.1.2 Specific objectives .....	5
<b>3.2 THE SIMULATION ENVIRONMENT</b> .....	<b>6</b>
3.2.1 Organisations.....	6
3.2.2 Sectorisation .....	7
3.2.3 Multi-aircraft Cockpit Simulator (MCS) .....	8
<b>3.3 TRAFFIC SAMPLES</b> .....	<b>9</b>
3.3.1 Creation of CVSM traffic samples .....	9
3.3.2 Creation of RVSM traffic samples .....	9
3.3.3 Flight level occupancy.....	10
3.3.4 Sector capacity .....	10
3.3.5 Specific conditions .....	11
3.3.6 Traffic samples used in Organisation 1 .....	11
3.3.7 Traffic samples used in Organisation 2.....	11
3.3.8 Traffic distribution .....	12
<b>3.4 OPERATIONAL PROCEDURES</b> .....	<b>14</b>
3.4.1 CVSM ATC Procedures .....	14
3.4.2 RVSM ATC Procedures .....	14
3.4.3 French Civil - Military co-ordination procedures .....	14
3.4.4 Short Term Conflict Alert (STCA).....	14
<b>3.5 CONSTRAINTS OF THE SIMULATOR</b> .....	<b>15</b>
<b>4. RESULTS</b> .....	<b>16</b>



<b>4.1 ANALYSIS .....</b>	<b>16</b>
4.1.1 Subjective analysis .....	16
4.1.2 Objective analysis .....	17
<b>4.2 SPECIFIC OBJECTIVE 1 .....</b>	<b>19</b>
4.2.1 Advantages of the Single FLOS .....	20
4.2.2 Advantages of the Double FLOS .....	20
4.2.3 Loss of separation analysis .....	21
4.2.4 Analysis of Level Changes to Solve Conflicts .....	23
4.2.5 Civil - Military Operations .....	25
4.2.6 The controllers preference, Single or the Double FLOS .....	26
<b>4.3 SPECIFIC OBJECTIVE 2 .....</b>	<b>28</b>
4.3.1 Analysis method .....	28
4.3.2 Graphs .....	29
4.3.3 Comparison between the morning and afternoon traffic samples .....	29
4.3.4 Comparison between traffic increase and workload increase .....	29
4.3.5 Comparison of 0% non-MASPS exercises .....	30
4.3.6 Comparison of 1% non-MASPS exercises .....	35
4.3.7 Comparison of 3% non-MASPS exercises .....	37
4.3.8 Comparison between various levels of non-MASPS exercises .....	38
4.3.9 Summary of workload results .....	41
4.3.10 Analysis of RFL .....	42
<b>4.4 SPECIFIC OBJECTIVE 3 .....</b>	<b>44</b>
4.4.1 Results of non-MASPS aircraft operations .....	44
4.4.2 Proposed general ATC procedures as developed by the APDSG .....	47
4.4.3 Results of study using a coloured Radar Label .....	48
4.4.4 Results of study on Flight Strips .....	49
4.4.5 Result of study on Phraseology .....	51
<b>4.5 SPECIFIC OBJECTIVE 4 .....</b>	<b>52</b>
4.5.1 Contingency procedures for individual aircraft .....	52
4.5.2 Contingency procedures for multiple aircraft (weather related contingency) .....	52
4.5.3 Results .....	53
<b>4.6 SPECIFIC OBJECTIVE 5 .....</b>	<b>54</b>
4.6.1 Organisation 2 - Reims re-sectorisation .....	54
4.6.2 Results .....	54
<b>5. CONCLUSIONS .....</b>	<b>55</b>
<b>6. RECOMMENDATIONS .....</b>	<b>57</b>





## ANNEXES

ANNEX A	MAPS OF SIMULATION AIRSPACE
ANNEX B	SIMULATION PARTICIPANTS
ANNEX C	OPERATIONS ROOM LAYOUT

## REFERENCES

Reference 1	NAT(North Atlantic)/RVSM Real time Simulation EEC Report 284	Author: A. Barff
Reference 2	Report on Continental RVSM Real-Time Simulation EEC Report 294	Author: N. Sylvester-Thorne
Reference 3	2nd Continental RVSM Real-Time Simulation EEC Report 309	Author: A. Barff
Reference 4	Facility Specification S08 ANT-RVSM EEC Internal Document	Author: R. Lane



## LIST OF ABBREVIATIONS AND ACRONYMS

<b>ANT</b>	<b>Airspace and Navigation Team</b>
<b>APDSG</b>	<b>ATM Procedures Development Sub-Group</b>
<b>ATC</b>	<b>Air Traffic Control</b>
<b>ATCC</b>	<b>Air Traffic Control Centre</b>
<b>ATM</b>	<b>Air Traffic Management</b>
<b>ATS</b>	<b>Air Traffic Services</b>
<b>CVSM</b>	<b>Conventional Vertical Separation Minima</b>
<b>DED</b>	<b>Division of EATCHIP Development</b>
<b>DFS</b>	<b>Deutsche Flugsicherung</b>
<b>EATCHIP</b>	<b>European Air Traffic Control Harmonisation and Integration Program</b>
<b>ECAC</b>	<b>European Civil Aviation Conference</b>
<b>EEC</b>	<b>EUROCONTROL Experimental Centre</b>
<b>FL</b>	<b>Flight Level</b>
<b>FLOS</b>	<b>Flight Level Orientation Scheme</b>
<b>GAT</b>	<b>General Air Traffic</b>
<b>HMI</b>	<b>Human Machine Interface</b>
<b>ICAO</b>	<b>International Civil Aviation Organisation</b>
<b>MASPS</b>	<b>Minimum Aircraft System Performance Specification</b>
<b>MNPS</b>	<b>Minimum Navigation Performance Specification</b>
<b>OAT</b>	<b>Operational Air traffic</b>
<b>ODL</b>	<b>Opposite Direct Level</b>
<b>OPS</b>	<b>Operations</b>
<b>ORG</b>	<b>Organisation</b>
<b>R/T</b>	<b>Radio Telephony</b>
<b>RVSM</b>	<b>Reduced Vertical Separation Minima</b>



## 1. INTRODUCTION

### 1.1 DEFINITION OF TERMS

#### 1.1.1 Conventional Vertical Separation Minima (CVSM)

CVSM is the current separation standard where flight levels above FL290 are separated by 2000 feet.

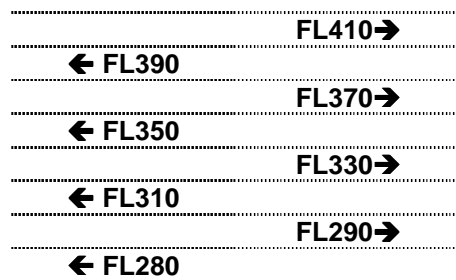

Figure 1- CVSM Flight levels

#### 1.1.2 Reduced Vertical Separation Minima (RVSM)

RVSM is an approved International Civil Aviation Organisation (ICAO) concept to reduce aircraft vertical separation from the CVSM of 2000 ft to 1000 ft, between Flight Levels (FLs) 290 and 410 inclusive. For RVSM implementation in European Civil Aviation Conference (ECAC) airspace two Flight Level Orientation Schemes (FLOSs) are proposed, the Single Alternate FLOS and the Double Alternate FLOS.



### 1.1.3 Single Alternate Flight Level Orientation Scheme

The Single Alternate FLOS is shown in the figure below. The standard 1000ft separation is extended up to FL410 retaining the convention : Even levels - westbound, odd levels - eastbound. It should be noted that the current westbound FLs 310, 350 and 390 become eastbound.

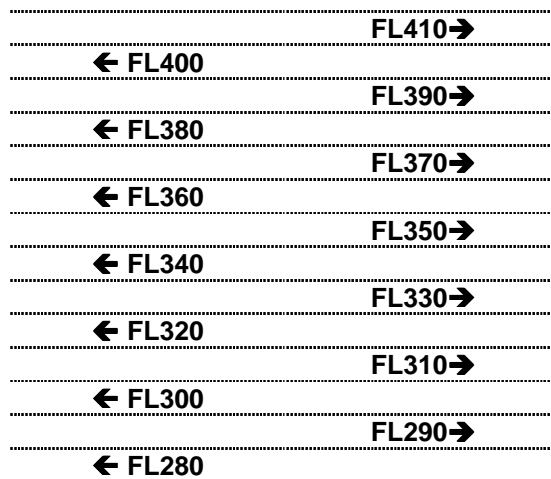

Figure 2- Single Alternate FLOS

### 1.1.4 Double Alternate Flight Level Orientation Scheme

The Double Alternate FLOS is shown in the figure below. In this FLOS the current flight level orientation is retained and each conventional level is supplemented by the RVSM level immediately above.

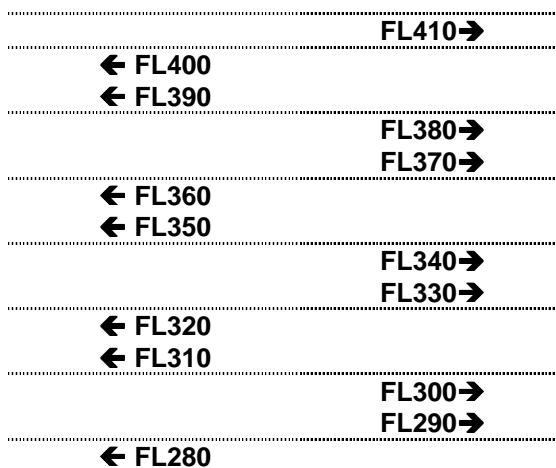

Figure 3 - Double Alternate FLOS

### 1.1.5 MASPS and Non-MASPS



MASPS (Minimum Aircraft System Performance Specification) is the certification to which aircraft must conform prior to operating in RVSM airspace. The majority of modern civil aircraft conform to MASPS but some older aircraft would need to be upgraded to comply. It is anticipated that there will still be a need to provide CVSM to a small number of State aircraft after the initial introduction of RVSM in continental Europe. The equipment required for MASPS certification includes having at least two independent altitude measurement systems, one secondary surveillance radar altitude reporting transponder, one altitude alert system and an automatic altitude control system.

**Non-MASPS** is the term used for an aircraft which does not conform to the MASPS specification.

### 1.1.6 State and Non-State Aircraft

A State Aircraft is one that is operated by the Military, Police or Customs.

All other aircraft are classed as non-State Aircraft.



## 2. RVSM BACKGROUND

In 1960, ICAO selected FL290 as the vertical limit for the 1000 feet CVSM, and 2000 feet was established for aircraft operating above FL290. This vertical limit was chosen based upon the accuracy of the barometric altimeters in use at that time.

To support the implementation of RVSM within Europe a series of real-time and fast-time simulations, and mathematical studies have been sponsored by the Airspace and Navigation Team (ANT) who are a sub -group of the European Air Traffic Control Harmonisation and Integration Program (EATCHIP). Several of these studies have been completed under the direction of the EUROCONTROL Experimental Centre (EEC).

In May 1994 the EEC conducted AR37 NAT(North Atlantic) /RVSM Real Time Simulation (report number EEC 284). This simulation studied operations within RVSM transition areas that will be required when RVSM is introduced in the NAT Region.

The first continental Real time RVSM simulation, AS16 Reims, was completed in May 1995 (report number EEC 294). This simulation was designed to investigate the operational implications associated with the use of RVSM over Continental Europe. This included the effects on civil/military communications. French, German and Swiss Flight/Upper Information Regions (FIRs/UIRs) were simulated with the assumption that all aircraft were MASPS certified.

The second continental Real time RVSM simulation, SA4 Hungarian, was completed in June 1996 (report number EEC 309). This simulation evaluated the operational advantages and disadvantages associated with the Single Alternate and Double Alternate FLOSs. The allocation of flight levels was studied on a tactical and strategic basis and non-MASPS traffic was included in the simulation.

On 27th March 1997 RVSM was introduced in the North Atlantic (NAT) Region between FL330 and FL370 in Minimum Navigation Performance Specification (MNPS) airspace. Flight levels are allocated according to the predominant traffic flow (easterly or westerly).

The decision to go ahead with RVSM implementation in the ECAC area was made by the ANT in June 1997. The RVSM (Ops) Task Force will recommend a FLOS to the ANT in October 1997, and the final decision for the FLOS will be made by the ANT by December 1997. RVSM implementation is scheduled for 2001.



### 3. THE S08 CONTINENTAL RVSM REAL-TIME SIMULATION

The third EUROCONTROL Continental RVSM Real time simulation (EEC Task S08) took place at the EUROCONTROL Experimental Centre, Brétigny-sur-Orge between 20th January and 14th February 1997. It continued to examine the application of the Single and Double FLOSs for use under RVSM conditions between FLs 290 and 410. The simulation also addressed the integration and procedures for non-MASPS certified aircraft and the recommendations from the second EUROCONTROL Continental RVSM Simulation (SA4 Hungarian) report number EEC 309.

#### 3.1 SIMULATION OBJECTIVES

##### 3.1.1 General objectives

1. To gain additional comparative results between the Single and Double Alternate RVSM FLOSs within a multi-ATC Centre European core area environment.
2. To confirm the suitability of the Double Alternate FLOS (as recommended by the RVSM OPS Task Force and as a result of previous RVSM simulations) within a multi-ATC Centre European core area environment.
3. To quantify the benefits of RVSM for the Air Traffic Management (ATM) system in the ECAC area.

##### 3.1.2 Specific objectives

1. To further evaluate the operational advantages and disadvantages associated with the strategic use of RVSM in the Single and Double FLOS against the CVSM reference.
2. To compare the controller workload and sector throughput between the RVSM reference traffic samples and 2 traffic samples with a higher traffic level using the Double Alternate FLOS.
3. To validate the proposed general ATC procedures as developed by the ATM Procedures Development Sub-Group (including ATC procedures to accommodate non-MASPS State Aircraft ) required for RVSM implementation using the Double FLOS.
4. To validate the proposed ATC contingency procedures based upon pre-described ATC contingency situations.
5. To determine the operational impact of a new vertical sector division FL345 within the Reims sectors UE and UH using the Double FLOS.



### 3.2 THE SIMULATION ENVIRONMENT

The objective was to provide a common operating platform that could be used by all the ATCCs participating in the simulation, that was easy to operate and required a minimal amount of training. All sectors used the same radar equipment and functionality, with flight data being displayed on paper strips. The strip format differed slightly between ATCCs. The Operations room layouts can be found at Annex C.

A full description of the operational and technical environment used in the simulation can be found in the S08 ANT-RVSM Facility Specification (Final version) available from EUROCONTROL, Bretigny.



**Figure 4 - The S08 Simulation Operations Room**

#### 3.2.1 Organisations

Two Organisations were used during the simulation. The majority of exercises was played during Organisation 1 which was the sectorisation and route network in use as of November 1996. Organisation 2 simulated a vertical sector split at FL345 in the Reims sectors UE and UH, and sector UF became part of the Reims Feed sector.





**3.2.2 Sectorisation**

The simulated area comprised of ATCCs from France, Germany and Switzerland (refer to maps in Annex A). The ten measured sectors are listed in the table below.

ATCC	SECTOR NAME	LOWER LIMIT	UPPER LIMIT
Karlsruhe	SOL	FL245	FL460
	TAN	FL245	FL460
Zurich	ZU2	FL285	FL345
	ZU3	FL345	FL460
Geneva	GE4	FL285	FL345
	GE6	FL345	FL460
Reims <b>ORG 1</b>	UE	FL195	FL460
	UF	FL195	FL460
	UH	FL195	FL460
Reims <b>ORG 2</b>	AE	FL195	FL345
	AH	FL195	FL345
	YE	FL345	FL460
Lyon (French Military)	MIL	FL195	FL460

Figure 5 below shows the layout of the four measured Swiss sectors, the two Geneva sectors are in the foreground and the two Zurich sectors in the background. On each sector the Executive controller is seated on the left with the Planning controller on the right.



**Figure 5 - The Swiss Sectors**



#### 3.2.3 Multi-aircraft Cockpit Simulator (MCS)

The MCS is a sophisticated pilot position developed at the EEC that allows the participation of professional pilots in real-time ATC simulations. The MCS was used for the period of the Simulation and was run in conjunction with the pseudo-pilot stations. An invitation was sent out to major European airlines prior to the Simulation requesting the participation of professional pilots in the Simulation.

Although some professional pilots did visit and fly the MCS, for most of the Simulation it was staffed by Eurocontrol personnel, and the feedback on RVSM matters from the professional pilots was regarded as minimal. For any real benefit to be gained from the MCS during a Real time Simulation similar to S08 it is suggested that pilots should visit on a regular basis (i.e. for a week or more) instead of on a day to day basis.



**Figure 6 - The Multi-aircraft Cockpit Simulator (MCS)**



### 3.3 TRAFFIC SAMPLES

#### 3.3.1 Creation of CVSM traffic samples

The CVSM traffic samples were created at the EUROCONTROL Experimental Centre. They were based upon a morning and afternoon traffic recording from Friday 24th May 96 supplied by the participating ATCCs. A morning and afternoon traffic sample was created as traffic flow varies according to the time of day. The samples were adjusted to include conflicting traffic situations within the measured sectors and to represent a traffic load equivalent to the present published sector capacity 1996 + 35%, + 55% and + 65%.

#### 3.3.2 Creation of RVSM traffic samples

To create the RVSM traffic samples, the CVSM traffic samples were duplicated and the copies renamed as either a Single or a Double traffic sample. The flight levels were then adjusted using the rules as proposed by EUROCONTROL Division of EATCHIP Development (DED) 4 shown in the tables below. The flights were chosen taking into account aircraft performance (some aircraft which can fly at FL370 are unable to reach FL390), and the distance of the flight (short/medium/long haul).

#### SINGLE ALTERNATE TRAFFIC SAMPLES

<b>FL390</b> →	FL400 - 50% FL380 - 50%	<b>FL370</b> →	FL390 - 50% FL370 - 50%
<b>FL350</b> →	FL360 - 40% FL340 - 60%	<b>FL330</b> →	FL350 - 40% FL330 - 60%
<b>FL310</b> →	FL320 - 70% FL300 - 30%	<b>FL290</b> →	FL310 - 60% FL290 - 40%

#### DOUBLE ALTERNATE TRAFFIC SAMPLES

<b>FL390</b> →	FL400 - 50% FL390 - 50%	<b>FL370</b> →	FL380 - 50% FL370 - 50%
<b>FL350</b> →	FL360 - 40% FL350 - 60%	<b>FL330</b> →	FL340 - 30% FL330 - 70%
<b>FL310</b> →	FL320 - 70% FL310 - 30%	<b>FL290</b> →	FL300 - 70% FL290 - 30%



### 3.3.3 Flight level occupancy

Note : In the CVSM exercises the flights flying at the RVSM levels are Military aircraft.

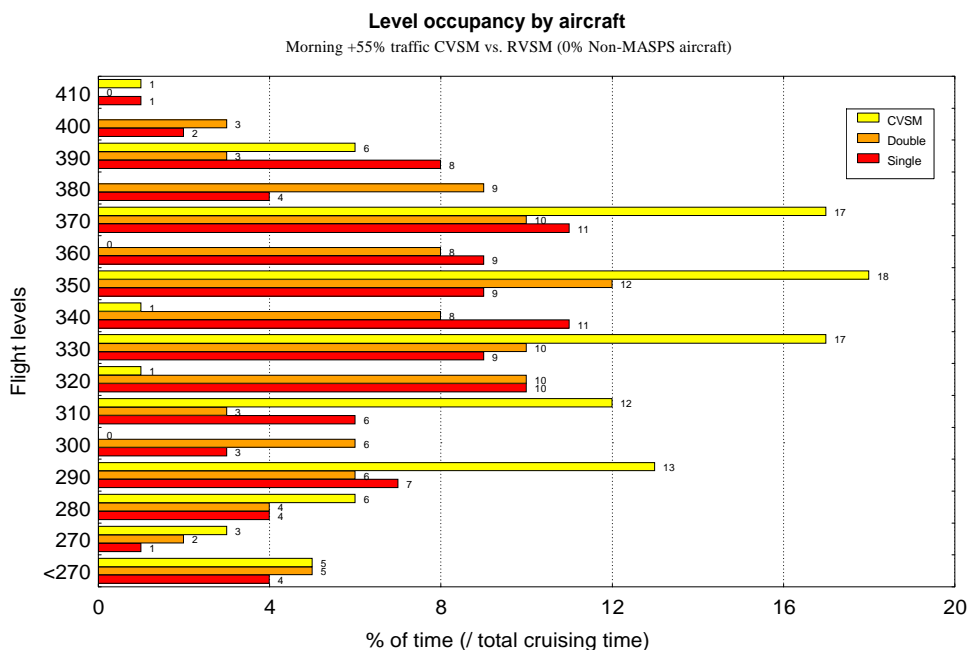

**Figure 7 - Flight level occupancy +55% traffic.**

Figure 7 details the distribution of flight levels (+55% traffic) between the different FLOSs.

### 3.3.4 Sector capacity

The table below details the declared 1996 sector capacity (number of aircraft per hour) and the guide figures used for the + 35%, + 55% and + 65% traffic samples. Some sectors have “ + number “ next to the declared 1996 capacity figure, this additional traffic was deemed to be necessary by the Project Leader to enable a sector workload to be reached so that the objectives could be achieved. The average number of aircraft which passed through each sector during the simulation varied from the planned figures due to different operational situations.

Sector Name	Declared 1996 capacity	1996+35%	1996+55%	1996+65%
GE4	35	47	54	57
GE6	28 + 5	44	51	54
ZU2	29 + 5	46	53	56
ZU3	32 + 5	50	57	61
SOL	54	73	83	89
TAN	41	55	63	68
UE	30 + 8	51	59	63
UF	26 + 8	46	53	56
UH	33 + 8	55	63	68
MIL	3 Tracks per controller	3	4	5



### 3.3.5 Specific conditions

The following conditions were applied to the traffic samples.

- The RVSM traffic samples included non-MASPS **non-State** and **State** Aircraft.
- The Non-MASPS **non-State** aircraft were restricted to FL290 or below.
- The measured hour for the morning sample was 0600-0700Z and the afternoon sample was 1500-1600Z.
- The non-MASPS **State** Aircraft flew as General Air Traffic (GAT) on the normal civil routes. The 1% level of non-MASPS traffic equated to about 1 aircraft per sector during the measured hour. The 3% level of non-MASPS traffic equated to between 2-4 aircraft per sector depending on the capacity of the sector.
- The Military traffic was controlled by the French Military and represented normal Operational Air Traffic (OAT) flying in eastern French airspace, crossing the civil routes, en-route to Military training areas.
- All Military OAT was simulated as non-MASPS certified.

A total of 57 exercises was completed ; four were training samples, two were exercises involving turbulence and the remaining fifty one were measured exercises. A breakdown of which exercises were played during the two organisations appears below.

### 3.3.6 Traffic samples used in Organisation 1

- 1996 +35%      6 x Reference      (CVSM)  
                     6 x Single FLOS      (3% non-MASPS)  
                     6 x Double FLOS      (3% non-MASPS)
- 1996 + 55%      2 x Reference      (CVSM)  
                     2 x Single FLOS      (All MASPS)  
                     3 x Double FLOS      (All MASPS)  
                     1 x Single FLOS      (1% non-MASPS)  
                     1 x Double FLOS      (1% non-MASPS)  
                     6 x Single FLOS      (3% non-MASPS)  
                     6 x Double FLOS      (3% non-MASPS)
- 1996+65%      4 x Single FLOS      (1% non-MASPS)  
                     2 x Double FLOS      (1% non-MASPS)

### 3.3.7 Traffic samples used in Organisation 2

- 1996+65%      3 x Single FLOS      (1% non-MASPS)  
                     3 x Double FLOS      (1% non-MASPS)



### 3.3.8 Traffic distribution

The following two graphs show the traffic distribution for the +35% and +55% morning traffic sample. The +65% traffic sample has not been included as there is only a small difference between it and the +55% traffic sample.

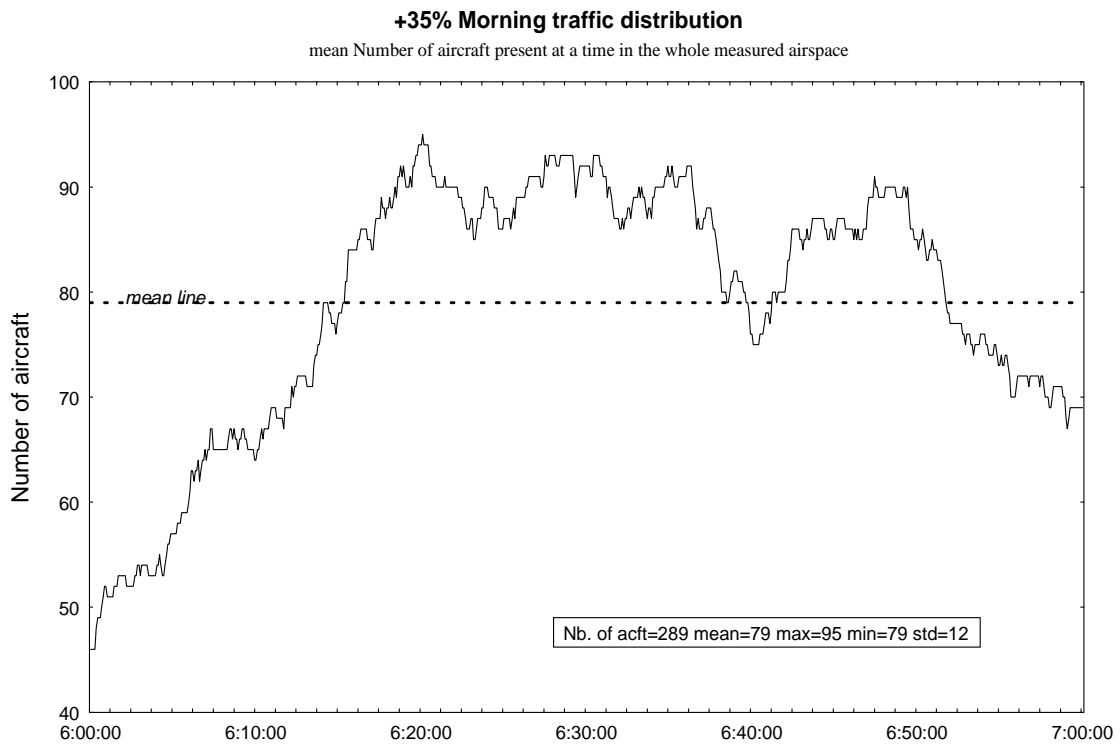
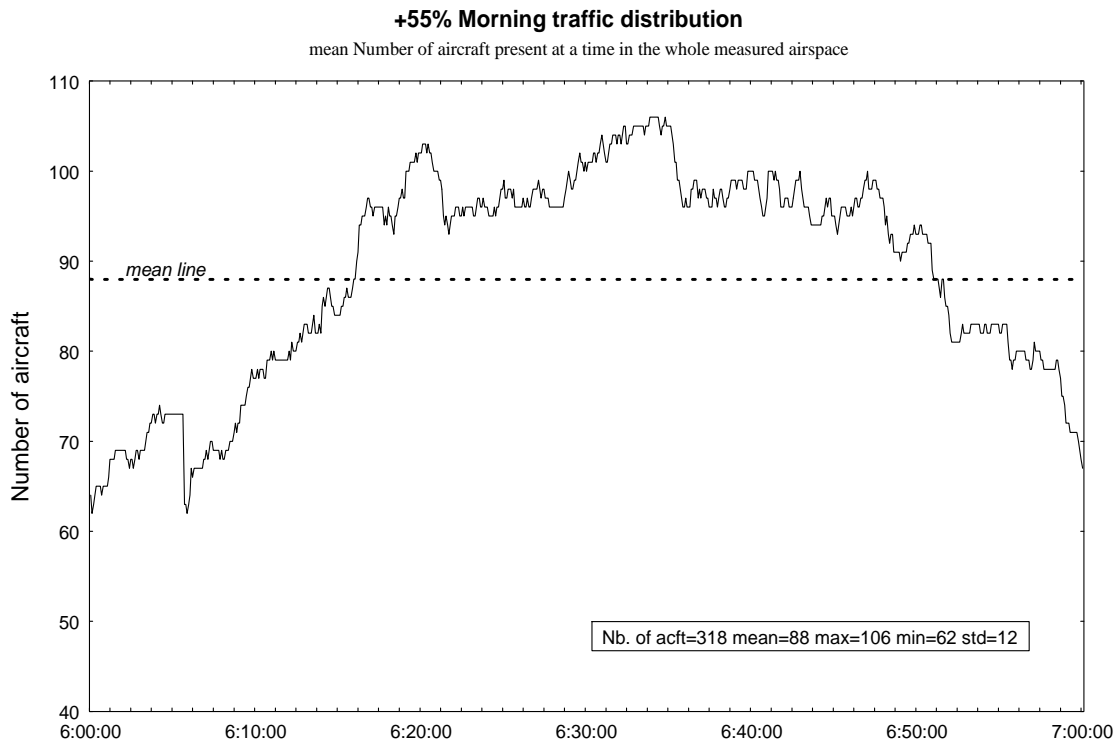

Figure 8 - Traffic load +35% morning traffic



**Figure 9 - Traffic load +55% morning traffic**



## 3.4 OPERATIONAL PROCEDURES

### 3.4.1 CVSM ATC Procedures

The ATC procedures used during the simulation were in accordance with current Letters of Agreement and/or particular Operational Instructions (with the exception of French Civil/Military co-ordination - see below).

### 3.4.2 RVSM ATC Procedures

MASPS compliant aircraft operating as **GAT** within RVSM airspace were to be provided with a minimum vertical separation of **1000 ft** or a lateral radar separation.

Non-MASPS compliant State Aircraft operating as **GAT** within RVSM airspace were to be provided with an increased minimum vertical separation of **2000 ft** or a lateral radar separation.

Non-MASPS compliant State Aircraft operating as **OAT** within RVSM airspace were to be provided with an increased minimum vertical separation of **2000 ft** or a lateral radar separation to ensure separation between OAT and GAT aircraft.

### 3.4.3 French Civil - Military co-ordination procedures

**NB. The following procedures were agreed only for the period of the simulation.**

The prevention of collisions was always the responsibility of the military controller. During periods of busy traffic a request for co-ordination could be refused by either the civilian or military controller.

For military flights crossing civil routes co-ordination was initiated by the military controller by telephone. The military controller gave the position and callsign of their traffic and the civil traffic, and the suggested course of action. The civil controller then either agreed or suggested an alternative solution.

A civil controller could have requested co-ordination to enter a military area, provided that 2 minutes warning was given and the subject aircraft and its intentions were pointed out to the military controller. The military controller then either agreed or suggested an alternative solution.

### 3.4.4 Short Term Conflict Alert (STCA)

The STCA parameters were programmed to determine the difference between the following categories of aircraft between FL290 and FL410 :

- MASPS certified aircraft and other MASPS certified aircraft.
- MASPS certified aircraft and non-MASPS certified aircraft.
- Non-MASPS certified aircraft and other non-MASPS certified aircraft.





## 3.5 CONSTRAINTS OF THE SIMULATOR

The following considerations should be taken into account regarding the results.

- It was agreed before the simulation to have a common radar functionality for all ATCCs. Although the majority of controllers quickly adapted to the functionality, some controllers felt that the lack of certain functions which are normally available at their own ATCC did affect their workload (i.e. the lack of a conflict predictor on the DFS sectors and not being able to highlight an aircraft outside of sector limits in the Swiss sectors).
- A controller will normally be able to handle an estimated 15-20% increase in traffic due to a syndrome called 'simulator effect' (simulated conflicts, predictable aircraft performance, compliant pilots, etc).
- Controllers often become familiar with the traffic samples. This is because each sample needs to be played a minimum of 3 times so that an average set of recorded data can be measured. Familiarity is countered by placing controllers in different working positions and varying the meteorological conditions (i.e. wind).
- The sectorisation used during the simulation was based on 1996 traffic levels. It is very unlikely that in the future, controllers will be handling traffic at the level of the traffic samples +55% and +65% using the same sectorisation. This was confirmed by the DFS controllers, who were working the SOL and TAN sectors from FL245-FL460 in the simulation, when normally they would operate these sectors with an Upper sector from FL345 to FL460. It was not possible to simulate the Upper sector due to the unavailability of controllers from Karlsruhe.



## 4. RESULTS

The description of the methods (Subjective and Objective analysis) used to collate the results follows this paragraph. The results are then detailed according to the five Specific Objectives (see section 3.1.2). The Conclusions of the results appears at section : 5.

### 4.1 ANALYSIS

#### 4.1.1 Subjective analysis

The subjective analysis is based on two different sources of information. The first source is the questionnaires (a total of 1060) given to the controllers before, during, and after the simulation. The second source is the Instantaneous Self Assessment method or ISA. Where appropriate questions asked on the questionnaires (indicated by a '**Q.**' followed by the text in bold italic letters) have been inserted. The answers to the questions appear below the question in normal text.

#### Questionnaires

**Note : The normal method of Controller workload assessment used at EUROCONTROL is ISA, however a parallel method was tested during the simulation where controllers were asked to assess their overall workload rating on a scale of 1-10 at the end of each exercise. These results were then subjected to statistical analysis and compared to the ISA recordings. The two sets of data reached the same conclusions, therefore some graphs showing the post exercise questionnaire results have been included for Objective 2 in order to emphasis certain results.**

Each post-exercise questionnaire included subjective evaluations on a scale from 1 to 10 of the following elements :

- the controller overall workload
- the R/T loading
- the degree of realism of the simulated traffic sample
- the difficulty in maintaining situational awareness

For each of these elements, the value 1 was considered to be Very Low, 5 as Moderate, and 10 as Very High. If a controller answered with a value of 6 or higher they were asked to give a brief reason why (i.e. traffic density, R/T loading, procedures, ...). The value of 6 indicates the point at which the effort/demand was considered to be higher than moderate.

From time to time, several questions were added related to the ATC aspect of the exercise or set of exercises already played.



#### Instantaneous Self Assessment (ISA)

The ISA method allowed the controller to assess his/her workload during the course of a simulated exercise. The controller was provided with a warning (Flashing light) every 2 minutes and had 30 seconds to register their perceived workload according to the following five point scale :

1 - Under-utilised, 2 - Relaxed, 3 - Comfortable, 4 - High, 5 - Excessive.

For presentation purposes, we aggregate the answers of the buttons 1 and 2 together as representing a situation where the controller is Relaxed or Very Relaxed and the answers of the buttons 4 and 5 together as representing a situation where the controller is Very Busy or Too Busy.

Experience shows that selection of either button 4 or 5 for more than 40% of an exercise means that the participant is likely to reject the organisation.

#### 4.1.2 Objective analysis

The Objective analysis is taken from data recordings made for each exercise. From these recordings the following factors are studied,

- Analysis of the loss of separation
- Analysis of the R/T occupancy
- Analysis of RFL
- Analysis of pilot orders
- Level Changes to Solve Conflicts

Most of the Objective Analysis concerned the controllers workload and is therefore directed mainly towards Specific Objective 2.

#### Analysis of the loss of separation

The Aircraft Proximity Index (API) is a measure designed to describe numerically the 'severity' of a loss of separation. It is calculated according to the separation minima in force for the airspace in question. The API shall be calculated as follows for En-Route sectors in RVSM scheme :

$$API = (1000 - D_v)^2 * (5 - D_h)^2 / 2.5E5$$

where  $D_v$  is the vertical separation in feet and  $D_h$  the horizontal separation in nm

The classification of « Very serious », « Serious », « Minor » is based on the following scale :

- |         |                |                  |
|---------|----------------|------------------|
| • 0     | =< API < 6.25  | « Minor »        |
| • 6.25  | =< API < 31.36 | « Serious »      |
| • 31.36 | >= API         | « Very serious » |

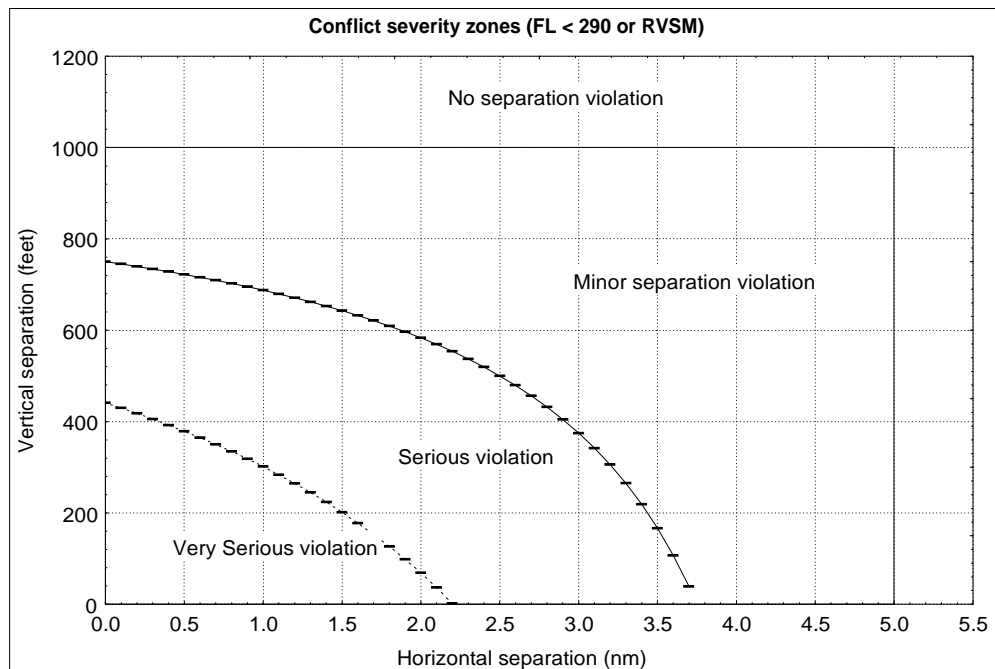

**Figure 10 : Aircraft proximity in vertical and horizontal terms**

The lateral separation minima was 5NM for every sector in the simulation. The STCA was activated to prevent lateral separation infringement of less than 5NM except for SOL and TAN sector where it was activated only under 3NM.

The vertical separation was 2000ft below FL290. Above FL290 the vertical separation was 2000ft for every aircraft in the CVSM exercises and reduced to 1000ft for all MASPS equipped aircraft in the RVSM exercises. A vertical separation of 2000ft was maintained for all Military and non-MASPS equipped aircraft even in the RVSM levels.



## 4.2 SPECIFIC OBJECTIVE 1

**To further evaluate the operational advantages and disadvantages associated with the strategic use of RVSM in the Single and Double FLOS against the CVSM reference.**

After the first 6 exercises of Single and Double FLOS a trend had developed where controllers working in a large vertically split sector with a lot of climbing and descending traffic generally preferred the Single FLOS and controllers working in a sector with a layer split which handled mainly cruising traffic generally preferred the Double FLOS. However by the end of the simulation following a change over of Zurich controllers after two weeks it was evident that preference of FLOS was based more on individual feelings than sector dimensions.

During the first set of Double FLOS exercises the question of vortex wake turbulence was raised regarding the safety rules for aircraft following in trail 1000' below a heavy category aircraft. This situation would potentially cause more concern in the Double FLOS than in the Single FLOS. For simulation purposes it was agreed that it could be assumed that no special criteria need be applied.

The second team of Zurich controllers pointed out that traffic arriving in their sector from the SW comes at Odd levels and has to be descended to Even levels when turning towards FUSSE. This caused a problem in the Double FLOS with traffic at FL350 which either needed to be climbed 3000' to FL380 or descended to FL340 which meant entering the ZU2 sector, requiring extra workload and co-ordination.

In the Single FLOS the traffic arrived at the Zurich sectors either at FL360 or FL340. The traffic at FL 360 can be descended to FL350 and remain in the upper sector and the traffic at FL340 is already in the lower sector and can be descended to FL330 and remain the lower sector. This required only 1000' change and no extra co-ordination and is one of the reasons the Zurich controllers preferred the Single FLOS. Much of the traffic passing through the Zurich sectors has to change level in the above mentioned way.

The Geneva sectors have a very complex route structure with 3 busy crossover points SPR/PAS/ROCCA. They handled traffic which entered and exited on the same flight level rule, and this made working in the Double FLOS easier for them.

**Q. Compared with CVSM, did you consider that separating aircraft with RVSM was :**

Much Easier	= 6%	Not Sure	= 6%
Easier	= 61%		
About the same	= 27%		
More difficult	= 0%		
Much more difficult	= 0%		



#### 4.2.1 Advantages of the Single FLOS

The controllers felt that the main advantages of the Single FLOS were as follows,

- A logical continuation of the FLOS in use today below FL290.
- An easy rule to remember, odd=east even=west, especially for the planning controller in the busier exercises. Many radar controllers relied heavily on the planners to arrange the flight levels for their traffic, this was due to the high R/T load and traffic complexity.
- Easy to plan non-MASPS traffic using different colour strip holders, i.e. if YELLOW strips were used for westbound traffic and BLUE for eastbound, if the non-MASPS was westbound in YELLOW, then any opposite direction conflicting traffic would be easily noticed in the BLUE strip holders above and below the non-MASPS strip in the strip bay.
- When the flight level parity reverses on a route (i.e. eastbound levels become westbound levels) it is less complicated to change to a new level as the opposite direction levels are directly 1000' above and below.
- Easier to do stepped climb and descents (it is understood that pilots would ideally prefer a continuous climb/descent, however with traffic at the +55% and +65% levels this was very difficult to manage). This was noted especially in the busier traffic samples when climbing or descending aircraft with poor performance i.e. it was easier to climb heavy outbound traffic through a 1000' layer of opposite direction traffic in the Single FLOS compared to 2000' in the Double FLOS.
- In the situation where traffic was converging at the same level, a 1000' climb /descent was often possible for a short period at an Opposite Direction Level (ODL) or on uni-directional routes.

***Q. In CVSM FL310, FL350, and FL390 are westbound levels. In the single FLOS exercises these flight levels became eastbound levels. By the end of the simulation did the reversal of these flight levels cause you any problems ?***

YES = 0%  
NO = 100%

#### 4.2.2 Advantages of the Double FLOS

The controllers felt that the main advantages of the Double FLOS were as follows,

- Easy FLOS to operate and to make the change from CVSM.
- In an area with many crossing routes it was easy to climb or descend 1000' to resolve converging conflicts.
- It was easy to revert to CVSM during the turbulence exercises and this would also apply for transition areas.
- If traffic is speed regulated in the same direction (i.e. the non-MASPS and MASPS traffic flying in the same direction is separated by 5 miles or more with the same speed) the non-MASPS aircraft might only need to be separated against one **opposite** direction level.



### 4.2.3 Loss of separation analysis

*Note : The STCA used during the simulation did not take into account an aircraft's CFL. Therefore, the STCA activated when an aircraft that was climbing or descending was potentially conflicting with other traffic within 2 minutes flying time regardless of the fact that a safe flight level may have been assigned.*

**Table of loss of separation +35% traffic samples (6 runs of each)**

FLOS	STCA	V. Serious	Serious	Minor
CVSM	305 (10)	4 (0/0)	6 (0/0)	59 (2/0)
Double	226 (58)	None	7 (1/2)	30 (1/4)
Single	286 (95)	3 (0/0)	12 (0/7)	46 (6/19)

**Explanation: X (A/B) X = Number of loss of separation, A=Number of Military OAT, B=Number of non-MASPS State aircraft. Except for STCA the number in brackets = non-MASPS State aircraft and Military OAT.**

The +35% traffic samples were the first exercises that the controllers experienced with RVSM. From the figures we can see that the Double FLOS and Single FLOS generated fewer "STCAs" than CVSM. The Single FLOS at this stage also generated more "STCAs" than the Double FLOS.

The Double FLOS also had fewer conflicts than the Single FLOS and CVSM (except for "Serious" conflicts which were about the same). There were also less non-MASPSs conflictions in the Double FLOS compared to the Single FLOS.

**Remark :** ZU2 had the highest number of STCA (77) and losses of separation (19) in CVSM, also in Double FLOS (46 STCA) and in Single FLOS (55 STCA). It is of interest that in the Single FLOS GE4 had a significantly higher amount of STCA (40) than in the Double (24) or CVSM (28).

**Table : Loss of Separation +55% morning traffic with 0% non-MASPS aircraft**

FLOS	STCA	V. Serious	Serious	Minor
CVSM	<b>128</b>	1	2	19
Double	94	1	2	11
Single	94	1	3	10

The +55% (0% non-MASPS) traffic samples showed that there was no noticeable difference between the Single and Double FLOS with STCA or Loss of Separation. There was a reduction in the number of STCA by about 26% between CVSM to RVSM. In terms of « Very Serious » and « Serious » losses of separation the three FLOSs are not significantly different, but there is an overall reduction of total losses of separation from CVSM to RVSM.



**Figure 11** shows the position of all the losses of separation during the +55% traffic runs and the different colours indicate which FLOS was being used at the time. It can be seen that the majority of incidents occur close to crossing points and sector boundaries, and it is at the crossing points that the controllers could potentially benefit from a FLAS by using agreed flight levels to automatically deconflict traffic coming from several directions.

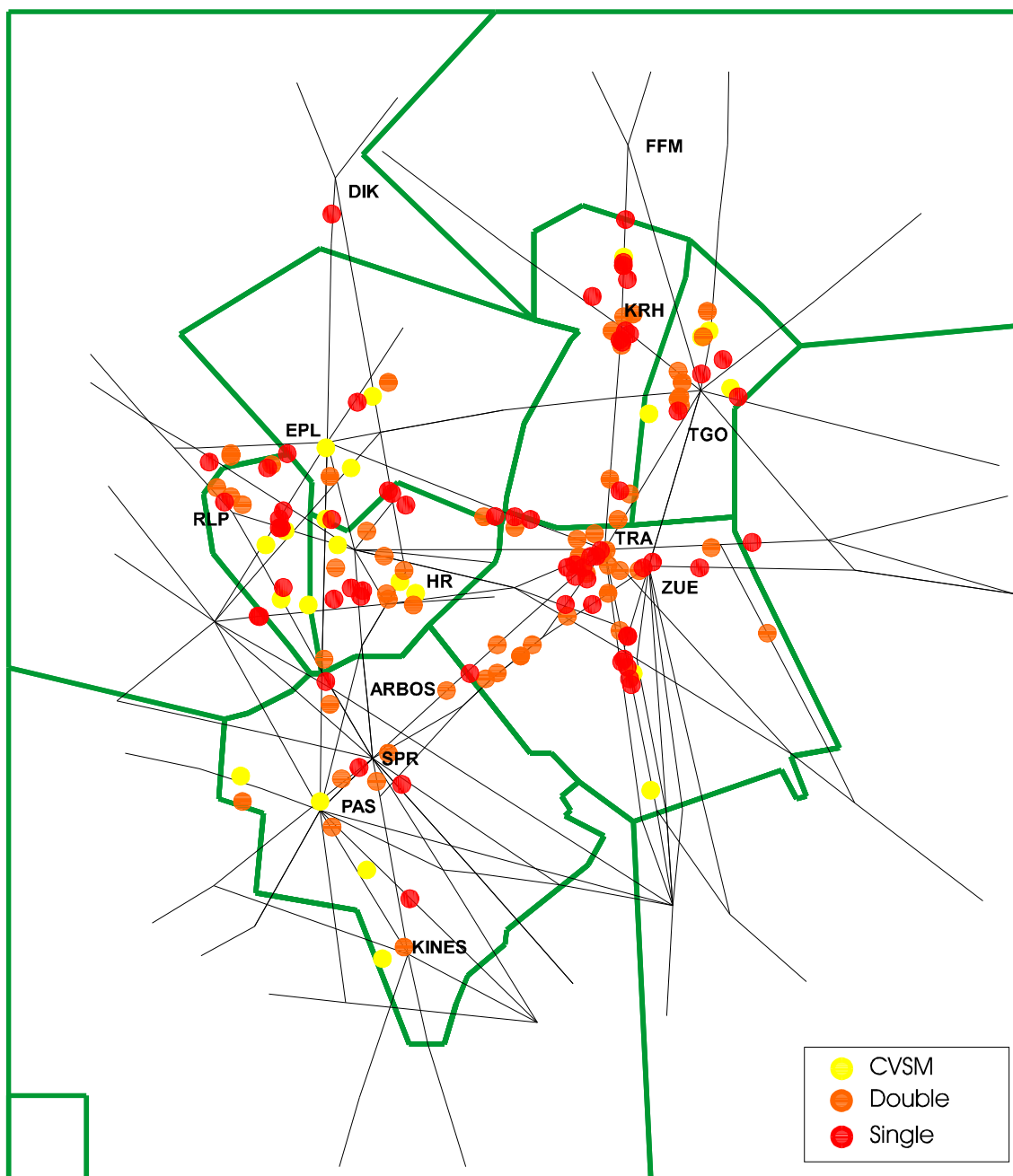

**Figure 11 . Map showing position of the Losses of Separation.**





**4.2.4 Analysis of Level Changes to Solve Conflicts**

Traffic recordings were analysed to detect where level changes were made to avoid a conflict. This was achieved by seeing if an aircraft received a level order of X thousand feet above or below its actual cruising level and then returned back to its original flight level. This is illustrated by the diagram below :



Analysis was made on flight level changes of 1000, 2000, or 3000ft depending on the FLOS used. For example, in CVSM this kind of avoidance can be made by a 2000 ft level change; with the RVSM Single alternate FLOS this can be made by a 1000 or 2000 ft level change depending on the type of the route (Uni/bi-directional); with the RVSM Double alternate FLOS this can be made by a 1000 or 3000 ft level change depending on the type of route (Uni/bi-directional).

**+35% Traffic Samples (3% non-MASPS)**

Analysis made on 3 x Morning and 3 x Afternoon exercises.

FLOS	1000 level change	2000 level change	3000 level change
CVSM	N/A	11	N/A
SINGLE	16 (5=Military and 5=non-MASPS)	6 (1=Military and 1=non-MASPS)	0
DOUBLE	10 (5=Military)	2 (1=non-MASPS)	0

In the +35% exercises the 1000 foot level change was used considerably more in the Single than in the Double FLOS. Sixteen 1000 foot changes were made in the Single FLOS, over half of which involved aircraft requiring 2000 feet separation, the controllers confirmed during debriefs that they used the 1000 foot level change in the Single FLOS for short periods to resolve conflicts or on uni-directional routes.

25 out of 45 of the level changes were aircraft which were climbed.



**+55% Traffic Samples (0% non-MASPS)**

Analysis made on 2 x Morning exercises.

FLOS	1000 level change	2000 level change	3000 level change
CVSM	N/A	6	N/A
SINGLE	4	4	0
DOUBLE	5	2	0

The 55% table above can not be directly compared to the +35% table as the number of exercise runs are different. However, the 55% table shows that the controllers used the 1000 foot manoeuvre the same amount of times as the 2000 foot manoeuvre in the Single FLOS, but in the Double FLOS the 1000 foot manoeuvre was favoured.

13 of the 21 level changes were aircraft which were climbed.

**+55% Traffic Samples (3% non-MASPS)**

Analysis made on 3 x Morning and 1 x Afternoon exercises in the Double FLOS and 2 x Morning and 3 x Afternoon exercises in the Single FLOS.

FLOS	1000 level change	2000 level change	3000 level change
SINGLE	17 (5=non-MASPS)	2	0
DOUBLE	14 (3=non-MASPS)	3	0

The table above shows that once again the 1000 foot manoeuvre is the most commonly used especially in the Single FLOS. 13 of the 36 level changes were aircraft which were climbed.

Most of the level changes in the +35% and +55% exercises lasted long enough to compensate for the fuel burned during the manoeuvres. It is interesting to note that the 3000 foot manoeuvre was never used during the simulation.



#### 4.2.5 Civil - Military Operations

The Military controllers identified two major requirements to enable them to safely operate OAT traffic within an RVSM environment.

1. The need for effective co-ordination with the civilian controllers, regardless of which FLOS is chosen. The reason for this being that civil aircraft will be using all levels currently used by the military, and with traffic levels similar to those seen in the simulation (especially at +55% and higher) it will be nearly impossible to cross busy civil routes with military traffic without co-ordination.
2. The Military controllers felt that they would need radar display and communication equipment similar to that used during the simulation to be able to perform their controlling tasks when RVSM levels are introduced. In particular the following items were considered to be of most value ;
  - A large coloured radar screen.
  - The ability to know the flight level intentions of the civil traffic.
  - A direct telephone line to the civil sectors.

All the Military controllers considered it easier working with RVSM compared to CVSM provided that they were able to co-ordinate with the civil controllers. They also considered that the amount of avoiding action required between the 2 FLOSs was very similar and they expressed no preference between the Single or Double FLOS.

**Q. Did you experience any confusion when the Single or Double FLOS was being used ?**

Not at all	= 100%
Occasionally	= 0%
All the time	= 0%

The following question was asked to the French **civil** and Geneva controllers.

**Q. Did the Civil / Military procedures used during the simulation assist you with your controlling task.**

YES	= 36%
NO	= 64%

The majority of controllers who answered NO, felt that the procedures did not assist their controlling task because the act of co-ordination increased their workload and took their attention away from the civilian aircraft.



#### 4.2.6 The controllers preference, Single or the Double FLOS.

After 8 days of simulation the controllers were asked which FLOS they preferred, 10 controllers preferred the Single FLOS, 5 preferred the Double FLOS and 5 considered it too soon to make a decision. It was agreed to continue to examine the Single and Double FLOS for the remainder of the simulation, and at the end of the simulation the controllers were again asked to indicate their preference, **the results taken from the final questionnaires are as follows,**

***Q. Taking all things into consideration, which FLOS did you prefer ?***

SINGLE	= 46% ( 11)
DOUBLE	= 33% ( 8 )
NO PREFERENCE	= 21% ( 5 )

Many of the controllers indicated that they could operate with either FLOS. The following question was asked to identify the operational factors which they considered would require further investigation before RVSM implementation.

***Q. Regardless of your chosen preference, do you think that there are any operational factors which would prevent the implementation of either the Single or Double FLOS in your airspace ?***

YES	= 47%
NO	= 53%

Where Yes was indicated the following reasons were given ;

- General procedures will need to be amended dependant upon which FLOS is chosen.
- The route network may need to be changed.
- Military procedures may need to be modified.
- It would be difficult to revert to CVSM using the Single FLOS.
- Emergency procedures need to be established.
- What are the controllers responsibilities in case of aircraft equipment failure where the aircraft no longer conforms to RVSM ?
- Is Vortex wake turbulence (where one aircraft is 1000 feet below and in trail following a heavy category aircraft) in the Double FLOS a hazard ?
- It would be difficult to do a gradual implementation in the Single FLOS.
- Transition areas would be required where RVSM airspace joins non-RVSM airspace and the Single FLOS could be more difficult to revert to CVSM in these areas.
- It is potentially more difficult to choose a sector split using the Double FLOS.
- Flow control procedures would have to be carefully applied so as not to overload the sectors.



**Q. By the end of the simulation, did either the Single or the Double FLOS cause you any confusion ?**

YES	= 60% →	Single	= 17%
		Double	= 83%
NO	= 40%		

**Q. Do you consider that there is a requirement for RVSM to be implemented on a gradual basis ( where initially the extra levels would be for controllers tactical use only; followed by a period of slowly introducing levels which can be flight planned by the aircraft operators until eventually all of the extra levels will be plannable)?**

YES	= 47%	
NO	= 53%	- RVSM could be introduced with all levels available to aircraft operators.



#### 4.3 SPECIFIC OBJECTIVE 2

To compare the controller workload and sector throughput between the RVSM reference traffic samples and 2 traffic samples with a higher traffic level using the Double Alternate FLOS.

**Note :** Due to the results of Objective 1 the Single Alternate FLOS was also compared in Objective 2.

##### 4.3.1 Analysis method

Workload analysis was only completed for Organisation 1. Organisation 2 was strictly a validation exercise for airspace reconfiguration.

An Analysis of Variance (ANOVA) was performed on various dependent measures with the following factors; FLOS (CVSM, Single, Double), Traffic % (1996+35%, +55%, +65%), Time (Morning, Afternoon), % Non-MASPS (0%, 1%, 3%), Sector (GE4, GE6, ZU2, ZU3, TAN, SOL, UE, UH, UF), and Position (Executive, Planner). Due to the simulation being limited to four weeks, replication was not possible at all levels and the sample size was quite small. Given these considerations, statistical analysis was completed in an attempt to answer the specific objectives of the simulation.

Specific Objective 2 was analysed as three sub-experiments according to the percentage of non-MASPS aircraft present during the run.

##### 1. Comparison of 0% Non-MASPS exercises

- Compare CVSM to Single to Double (+55% traffic) morning
- Compare CVSM +35% to Single and Double (+55% traffic)

##### 2. Comparison of 1% Non-MASPS exercises

- Compare Single to Double, (+55% traffic) morning
- Compare Single to Double, (+65% traffic)

##### 3. Comparison of 3% Non-MASPS exercises

- Compare Single to Double (+35% traffic)
- Compare Single to Double (+55% traffic)

##### 4. Comparison between various levels of non-MASPS exercises

- Compare 0% to 3% non-MASPS (+55% traffic) morning
- Compare CVSM to 3% non-MASPS (+35% traffic)
- Compare CVSM to 3% non-MASPS (+55% traffic)
- Compare CVSM (+35% traffic) to 3% non-MASPS (+55% traffic)
- Compare CVSM (+55% traffic) to 1% non-MASPS (+55% traffic) morning

Results were significant at  $\alpha = .05$ . It should be noted that due to the small number of runs the same data set was used for multiple comparisons. This may have affected the alpha level. Statistics will only be reported for significant results. Each dependent measure was analysed with the greatest number of interactions possible. If higher order interactions were not significant the measure was re-analysed with fewer interactions. Workload data was analysed with a covariate of number of aircraft.

Because the sectors are unique it is expected that there will be a different average workload for each. The purpose of the experiment was not to determine the difference between sectors.



Where there was no statistical difference within a factor, data was collapsed and discussed at a higher level.

Analysis focused on the specific objectives and controller comments made during the exercises. In particular, controller's claimed that the introduction of non-MASPS affected their ability to control aircraft under RVSM. Moreover, those that preferred the Single FLOS commented that it was easier to accommodate non-MASPS aircraft. They also commented that the introduction of non-MASPS aircraft reduced the benefits of RVSM regardless of the FLOS and that the Single FLOS was easier than the Double for the planning controller.

#### 4.3.2 Graphs

The scale used on the Controller workload graphs indicates the Subjective workload. Controllers were asked on questionnaires after each exercise to assess their workload from 1-10, with 1 being very low, 5 being moderate and 10 being very high. Answers of 6 or above were considered to be higher than moderate, and controllers who answered with a score 6 or above were asked to give a brief reason why their workload had been high (i.e. traffic density, R/T loading, procedures etc).

#### 4.3.3 Comparison between the morning and afternoon traffic samples

Morning and afternoon traffic samples were compared for each non-MASPS category i.e., 0%, 1%, and 3%. The original intention was to have the sector traffic load (see sector capacity 3.3.4) in both traffic samples the same, however due to traffic flow and operational constraints a significant difference was found between the morning and afternoon. Because the period (morning or afternoon) of the sample had a statistically significant effect on controller workload ratings, where possible morning and afternoon values were analysed independently.

#### 4.3.4 Comparison between traffic increase and workload increase

To support the hypothesis that an increase in traffic would result in an increase in controller workload when all other conditions are kept constant comparisons were done on the following: +35% vs. +55% traffic for CVSM.

Almost all observed average workload values for all sectors increased when the traffic level increased. Some of these increases were found to be statistically significant. The exception to this was during the +55% Afternoon traffic with 3% non-MASPS aircraft. Here, sectors SOL and UH had a slightly higher observed average workload but the difference was neither practically or significantly different.



4.3.5 Comparison of 0% non-MASPS exercises

**Analyse FLOS: Compare CVSM to Single to Double (+55% traffic) morning**

Analysis showed a significant decrease in average workload between CVSM and the Single FLOS, and CVSM and the Double FLOS, but no significant difference between the Single and the Double FLOS (see Figures 12 and 13). All sectors experienced a decrease in average workload during RVSM compared to CVSM regardless of the FLOS used.

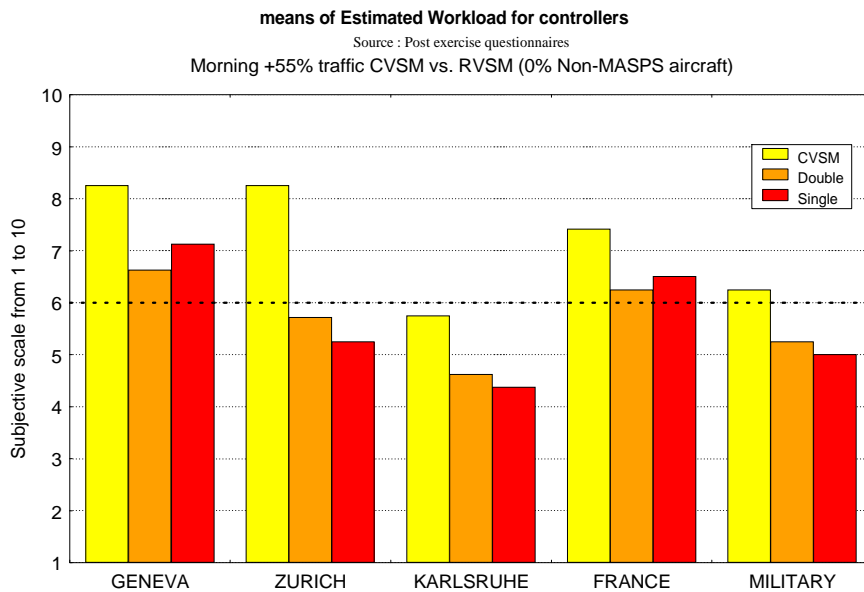

Figure 12 - Source post questionnaires

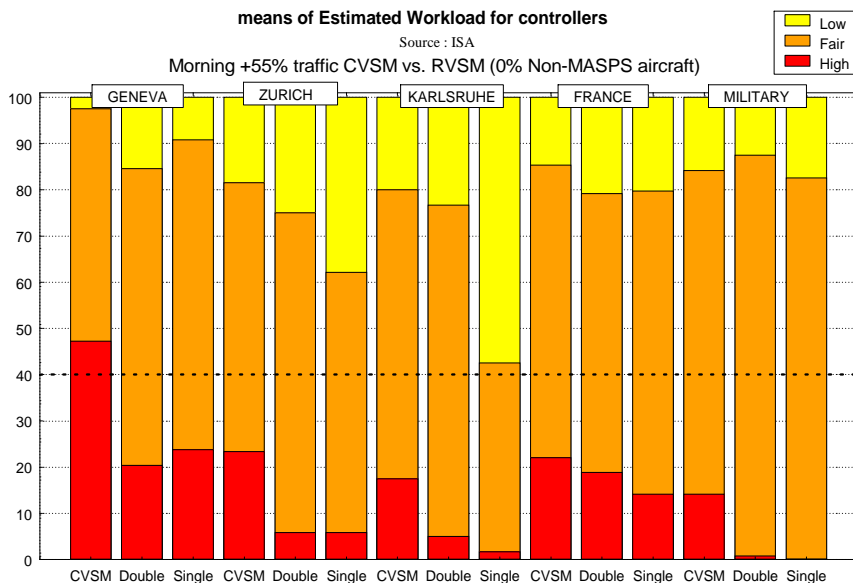
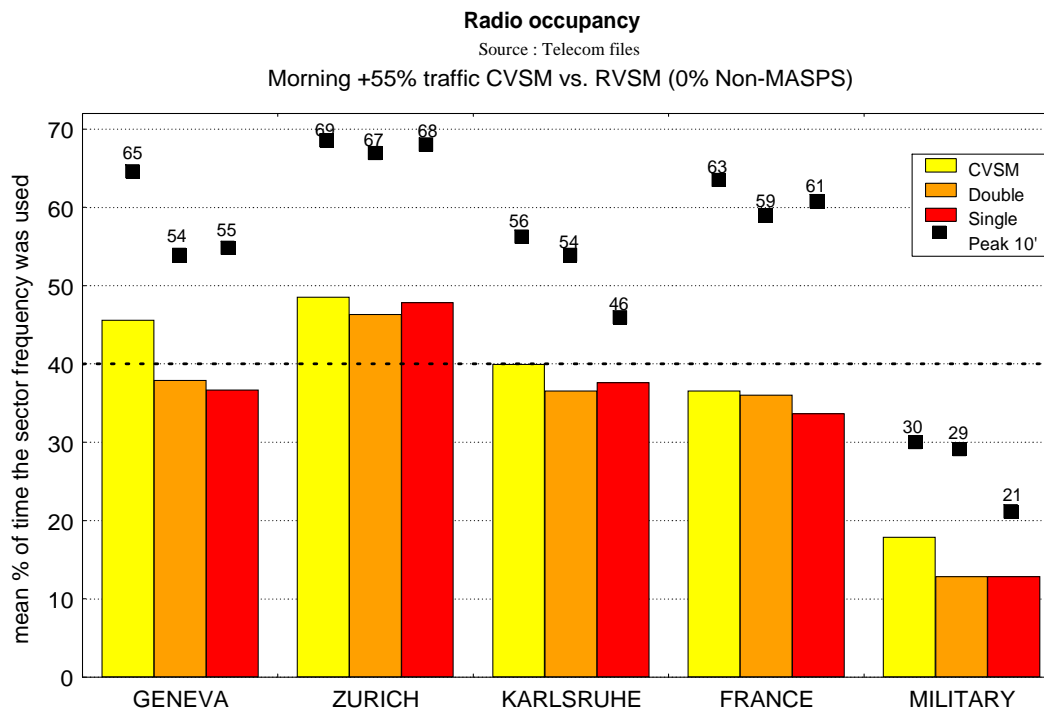

Figure 13 - Source ISA





R/T LOADING



**Figure 14 - Radio occupancy +55% traffic**

The R/T communication for most of the ATCCs is very high in CVSM and RVSM. The only reduction is for GENEVA and French MILITARY. The results are high due to the busy traffic samples and congested airspace and this was supported by the controllers during the debriefings and in the post exercise questionnaires.

*It should be noted that in the Second Continental RVSM Simulation the R/T levels were below 40% and during the 10 minute peak did not rise above 50%.*



### Pilot orders

Order	+55% CVSM	+55% Double 0% non-MASPS	+55% Single 0% non-MASPS	+55% Double 3% non-MASPS	+55% Single 3% non-MASPS
Direct	383	309	327	325	345
Expedite	28	15	19	24	24
Heading	172	99	111	134	140
Level	300	314	306	303	321
Speed	25	21	15	19	18
Total	908	758	778	805	848

The figures in the table above represent the mean of total number of each group of pilot orders for each FLOS. This table gives an overview of the majors groups of orders given by the controllers to the pilots. This comparison is based on 2 exercises for each FLOS and the numbers are averaged.

The total number of orders between CVSM and RVSM is reduced (by up to 14% in the 0% non-MASPS exercises). Most of the differences between the Single and Double FLOS are insignificant, however in both the 0% and 3% non-MASPS exercises there is a significant reduction of DIRECT orders in the Double FLOS. There is also a significant reduction in HEADING orders in both FLOSs compared to CVSM.

Due to the extra levels available with RVSM it is not surprising that the level orders show a slight increase, however all the other orders show a decrease the most noticeable being heading orders which are generally given to resolve conflicts.

The track histories (**Figures 15 and 16**) detail the same exercise and area using CVSM and RVSM (the Double FLOS is shown here, however the Single is very similar).

The **Figure 16** (the RVSM exercise) shows that generally aircraft were kept on the standard routes especially near to the major crossing points KRH, TRA and ZUE compared to the CVSM exercise. The tracks shown off-route were consistent with direct routeings given during the simulation. Forward planning is often made easier if an aircraft stays on its route opposed to being given headings to avoid conflicting traffic. Analysis has shown that less headings were used during RVSM exercises compared with CVSM which meant that controllers did not need to allocate time monitoring individual aircraft on headings, less time was spent on the R/T allowing other tasks to be performed and aircraft were still able to get direct routeing when it was advantageous as less traffic was being radar vectored off-route.

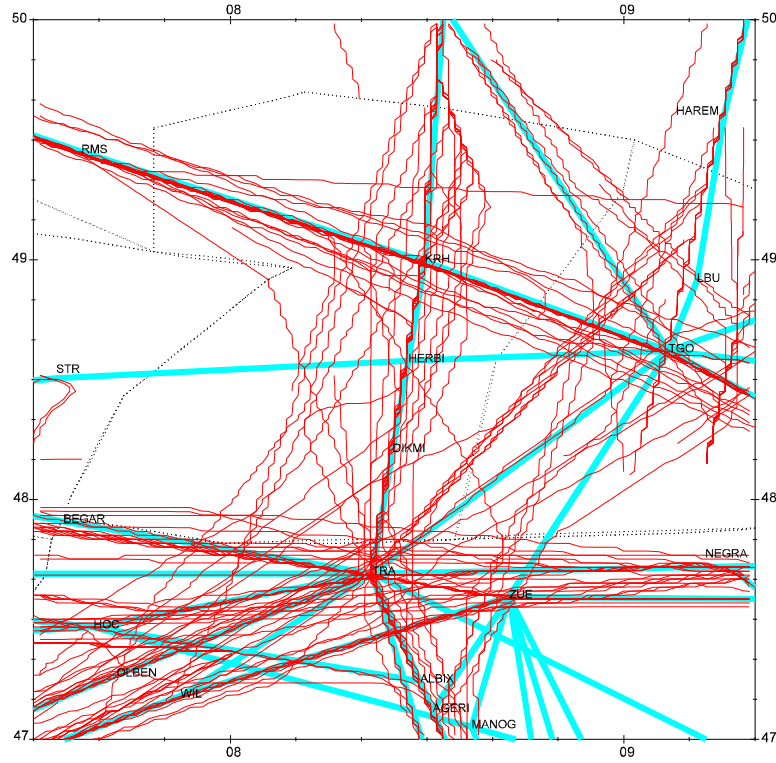

Figure 15 - Flight tracks using CVSM levels

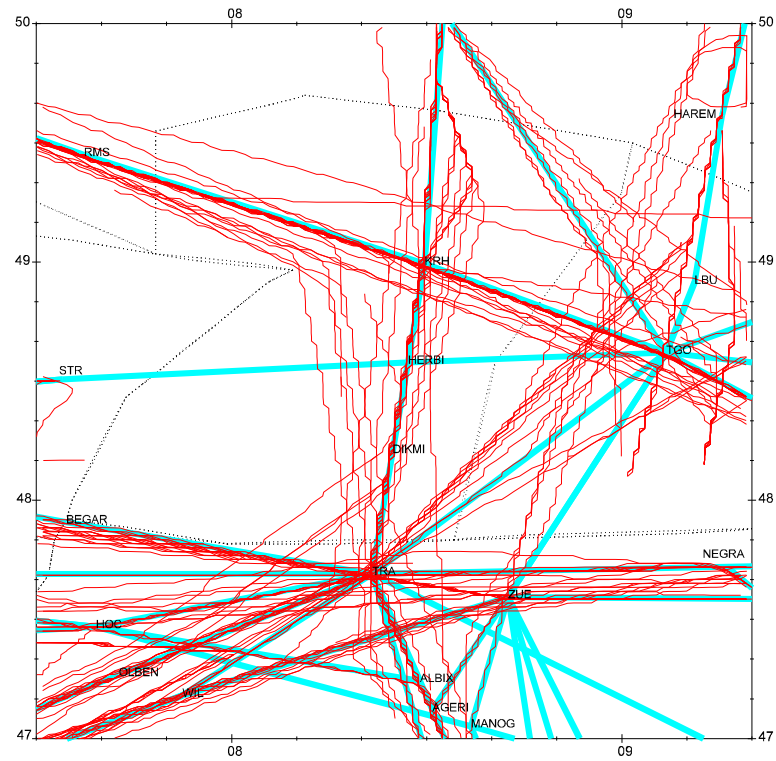
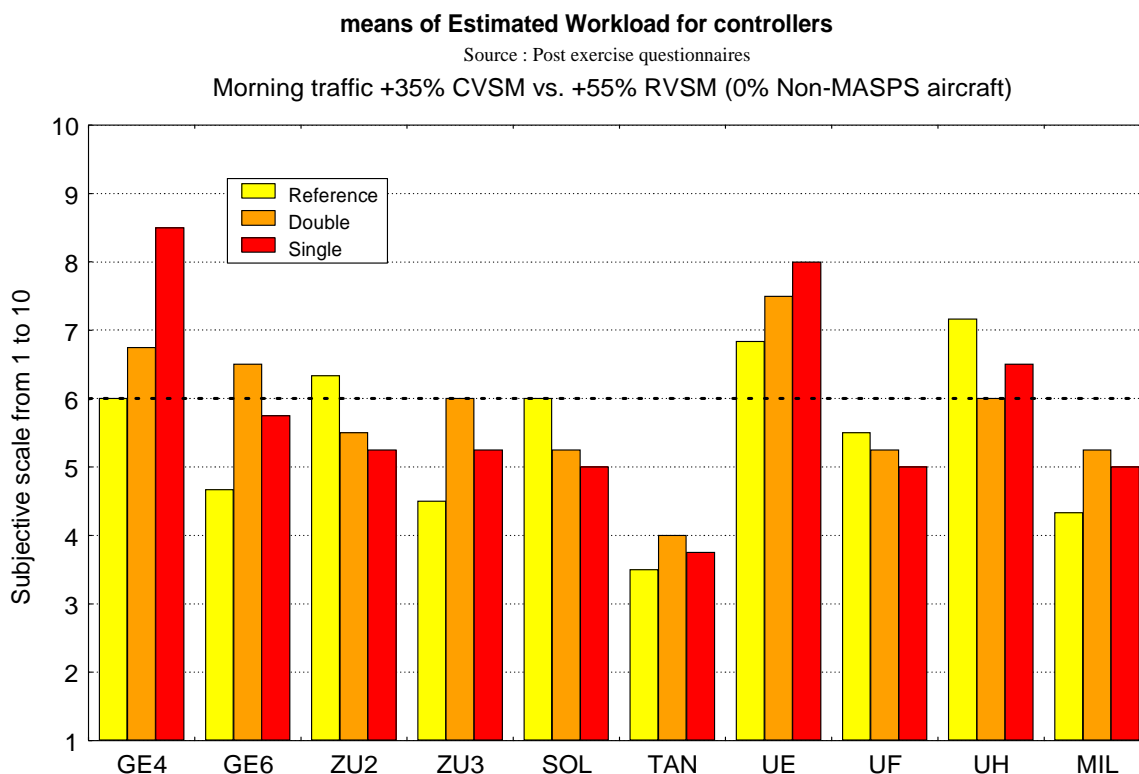

Figure 16 - Flight tracks using RVSM levels.



**Analyse effect of RVSM: Compare CVSM +35% to Single and Double (+55% traffic)**

It is expected that RVSM implementation will help increase sector capacity. Controller comments supported this claim. Controller workload between CVSM at the +35% traffic level was compared to RVSM at the +55% traffic level. Analysis showed that the increase in traffic with RVSM did not significantly effect controller workload (see Figure 17) however, three sectors did experience higher workload Sector GE4 had a significantly higher workload for the Single at +55% traffic than CVSM at +35% and sectors GE6 and ZU3 had a significantly higher average workload for the Double FLOS at +55% than CVSM at +35%.



**Figure 17 - Controllers workload +35% vs +55% (0% non-MASPS)**



4.3.6 Comparison of 1% non-MASPS exercises

**Analyse FLOS: Compare Single to Double, (+55% traffic) morning**

Due to time constraints only one run in each FLOS was possible however, no noticeable differences in average controller workload between the Single and Double FLOS were found.

**Analyse FLOS: Compare Single to Double, (+65% traffic)**

The +65% traffic samples were played with only 1% non-MASPS traffic. Many of the controllers were operating at, or very close to their capacity and much of the workload was attributed to the heavy R/T loading.

Morning - Analysis showed that some sectors showed a significant difference in the average workload ratings between the Single and the Double FLOS at the +65% traffic level. Sectors GE4 and ZU2 had an observed higher average for the Single and the difference in GE4 was statistically significant. All other sectors had an observed average workload that was equal or higher for the Double FLOS rather than the Single FLOS. Of these, the differences in sectors GE6, SOL, ZU3, and MIL were statistically significant (see Figure 18).

Afternoon - Not enough runs were completed for analysis. However, a higher average rating was given for the Single FLOS for sectors GE6 and UE. All other sectors reported an equal or higher average for the Double FLOS.

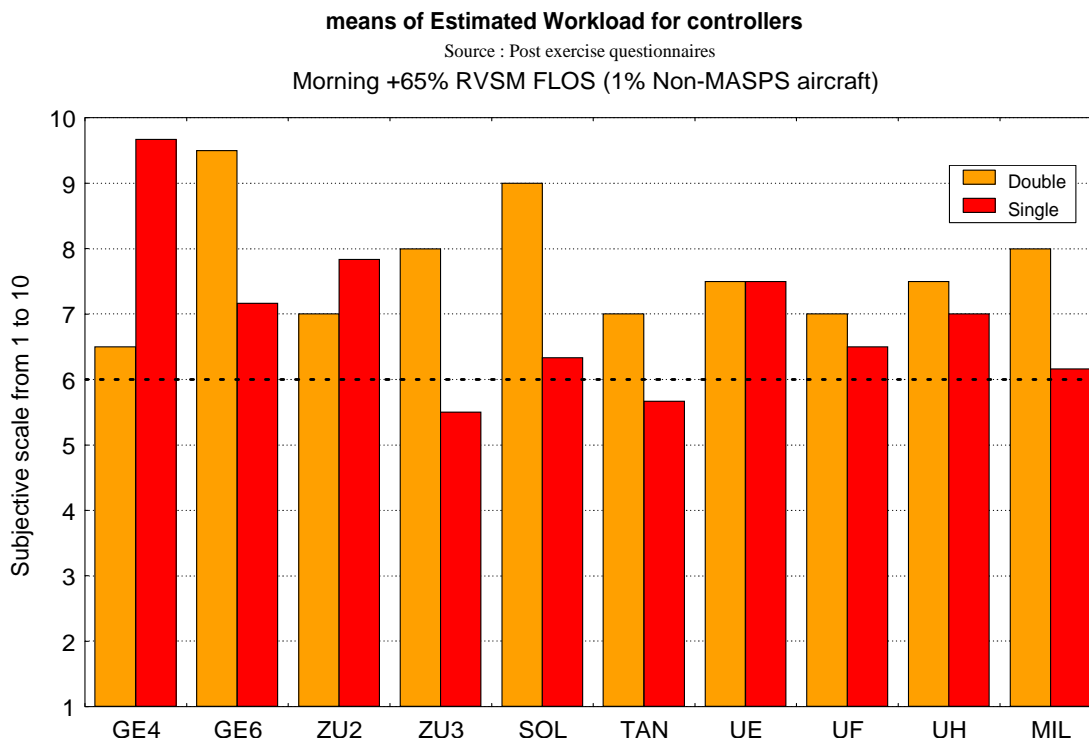
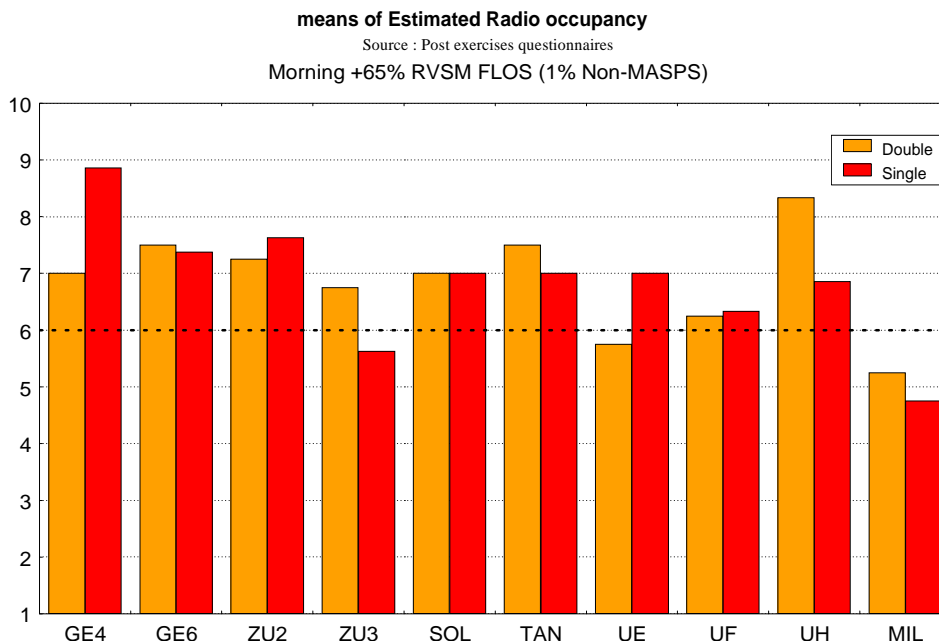

**Figure 18 - Controller workload +65% traffic**



**R/T loading**

There was a failure of the Telecom recording equipment during the +65% exercises, however from the questionnaire responses below nearly all the controllers reported very high R/T loading (above 6 on the scale). This was confirmed during debriefings and with this level of traffic controllers were only able to cope because of the predictable response from the simulator pilots. Many commented that the same situation in real life would be very dangerous if one aircraft either missed a call, was slow to turn, had a problem or blocked the frequency.



**Figure 19 - Radio occupancy +65% traffic**

The R/T communication for most of the ATCCs is very high in CVSM and RVSM. The only reduction is for GENEVA and French MILITARY. The results are high due to the busy traffic samples and congested airspace and this was supported by the controllers during the debriefings and in the post exercise questionnaires.



4.3.7 Comparison of 3% non-MASPS exercises

**Analyse FLOS: Compare Single to Double (+35% traffic)**

Morning - Some sectors had a lower average workload with the Single FLOS and others with the Double FLOS. For the overall airspace there is no significant difference between the Single and the Double FLOS (see Figure 20).

Afternoon - Analysis shows no significant difference between the Single and Double FLOS. While each sector may show slightly different averages, none are significantly different (see Figure 20).

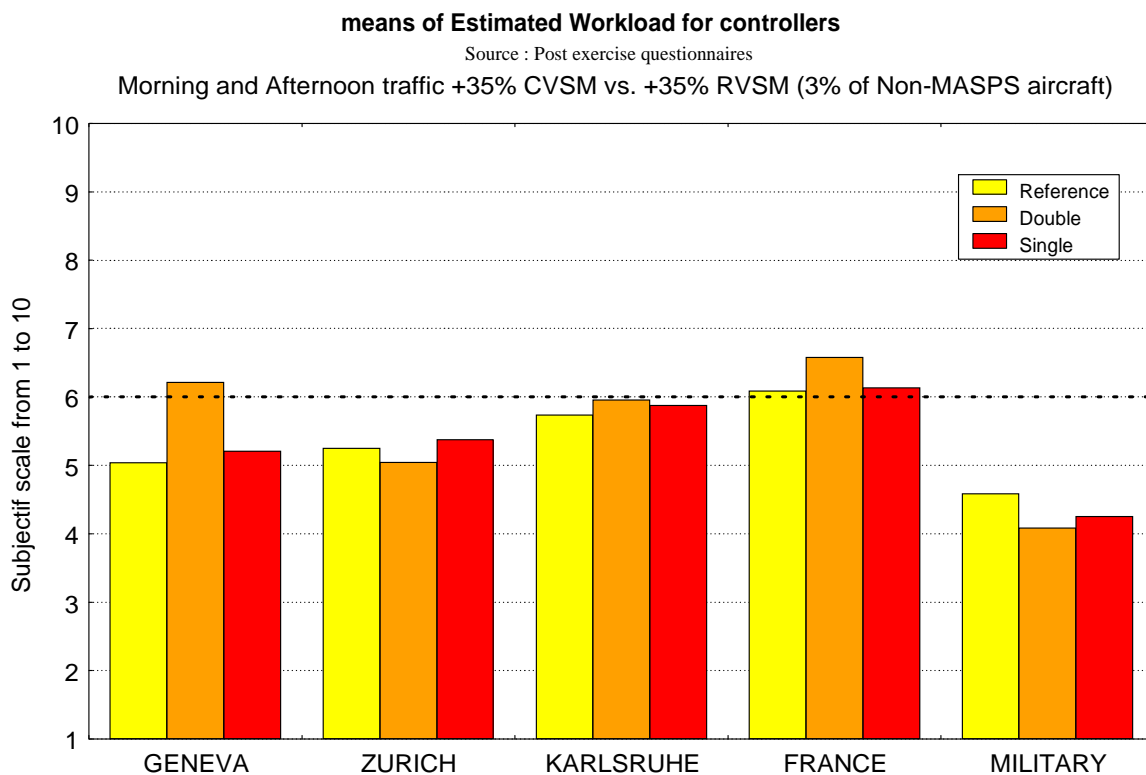

**Figure 20 - Controllers workload CVSM vs. RVSM +35% traffic.**

**Analyse FLOS: Compare Single to Double (+55% traffic)**

The analysis for the Morning and Afternoon samples shows no significant difference between the Single and the Double FLOS. While each sector may show slightly different averages, none are significantly different (see Figure 23).



4.3.8 Comparison between various levels of non-MASPS exercises

Controllers commented that non-MASPS aircraft reduced the benefits of RVSM. In support of this a comparison between the same traffic with 0% and 3% non-MASPS aircraft was made. It is expected that RVSM will be implemented allowing non-MASPS traffic in RVSM airspace, therefore a comparison between CVSM and RVSM with 3% non-MASPS was also made to see the effects on controller workload.

The following analysis supports controller comments. **The inclusion of non-MASPS aircraft increased the average controller workload.** Also the benefits of RVSM seem to be lost when these aircraft are flying in the airspace. Controller workload is not decreasing significantly from CVSM traffic to RVSM traffic when 3% non-MASPS aircraft are present.

**Analyse Non-MASPS: Compare 0% to 3% non-MASPS (+55% traffic) morning**

All sectors had an observed increase in average workload during RVSM exercises with 3% Non-MASPS aircraft compared to 0% non-MASPS. The increase was statistically significant for sectors GE6, SOL, ZU2, UH, and MIL (see Figure 21).

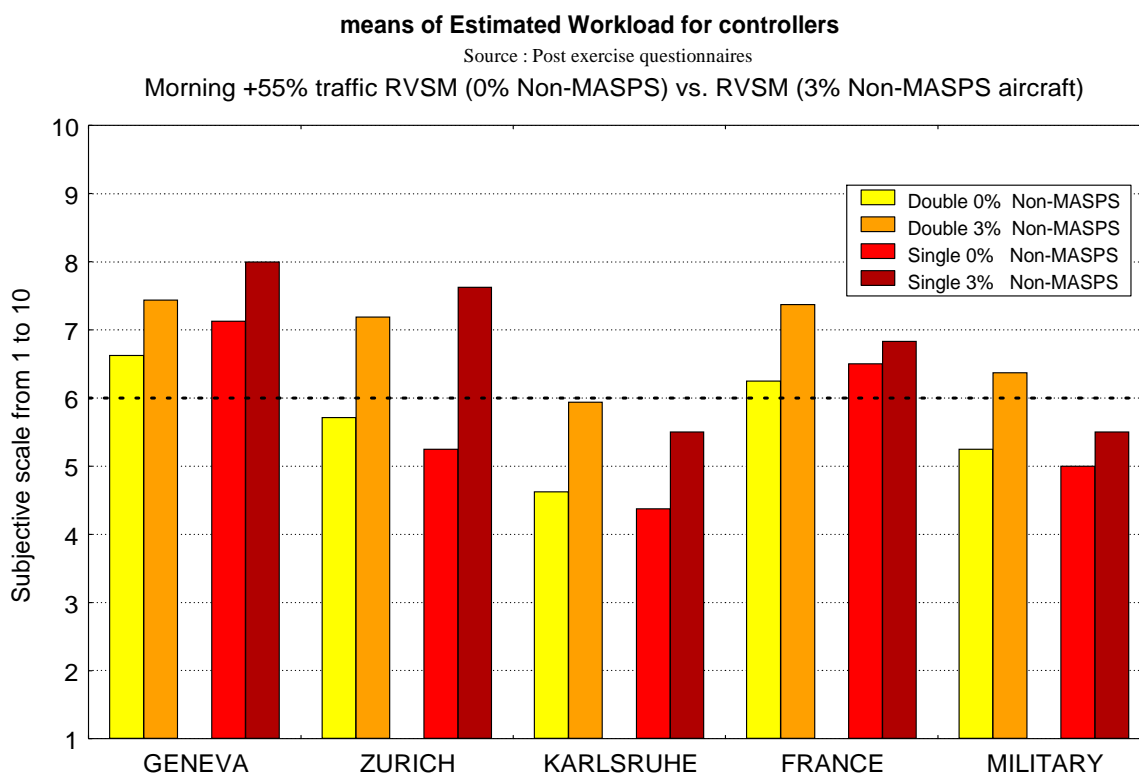

**Figure 21 - Controller workload +55% RVSM (0% vs 3% non-MASPS)**





**Analyse CVSM to RVSM: Compare CVSM to 3% non-MASPS (+35% traffic)**

The first exercises played were +35% CVSM. Most of the controllers found the samples to be similar to the load on a busy summer’s day, only 1 or 2 controllers considered that they were running out of flight levels to resolve conflicts.

Analysis shows no significant difference in controller workload between CVSM and RVSM with 3% non-MASPS at the 35% traffic level for both the morning and afternoon traffic samples (see Figure 20).

**R/T Loading**

There was no significant difference in R/T loading between the 3 FLOS at +35% level of traffic. All sectors except the Military averaged busy scores with the 10 minute peak levels above 50%.

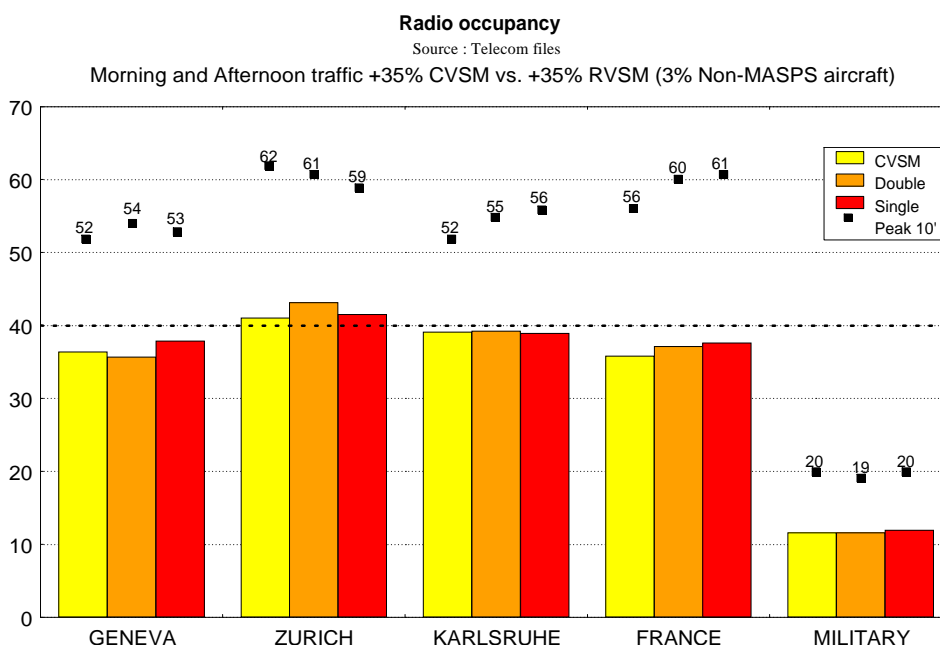

**Figure 22 - R/T loading +35% exercises.**

**Analyse CVSM to RVSM: Compare CVSM to 3% non-MASPS (+55% traffic)**

The observed averages for the Single and the Double FLOS were slightly lower than the observed average for CVSM morning samples. However, analysis shows that there is no significant difference between CVSM and RVSM with 3% non-MASPS at the +55% traffic level for the morning traffic samples.



**Analyse CVSM to RVSM: Compare CVSM (+35% traffic) to 3% non-MASPS (+55% traffic)**

Analysis shows that the Single and Double FLOS at +55% had significantly higher average workload values than CVSM at +35% (see Figure 23).

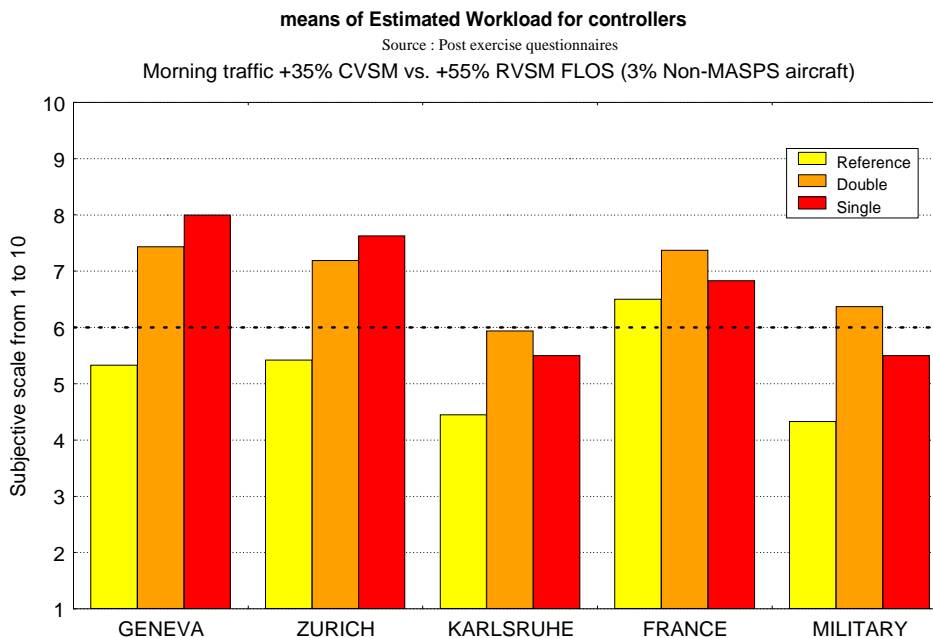

**Figure 23 - Controller workload +35% CVSM vs. +55% RVSM (3% non-MASPS)**

**Analyse CVSM to RVSM : CVSM (+55% traffic) vs. 1% non-MASPS (+55% traffic) morning**

***Note : Only one exercise run in each FLOS was completed, therefore these results should be used as an indication only and further study is recommended to validate the reduction in controller workload.***

The results from the morning traffic samples show that both the Single and the Double FLOS had a lower workload value than CVSM. Analysis shows that the Single FLOS was lower than CVSM and the Double FLOS was lower than CVSM but the Single FLOS was not significantly different to the Double FLOS.



#### 4.3.9 Summary of workload results

- An increase in traffic created higher workload (based on data where all variables like FLOS stay constant and only the traffic level is increased, **(see Figures 12/13 and 23)** for a comparison between +35% and +55% CVSM Morning traffic)
- There was no significant difference in average workload between the Single and the Double FLOS at +35% and +55%, however at +65% some sectors differed but there was no clear trend towards the Single or the Double FLOS **(see Figures 12/13, 18 and 20)**.
- All sectors had an observed increase in average workload during +55% RVSM exercises with 3% non-MASPS aircraft compared to +55% RVSM with 0% Non-MASPS **(see Figure 21)**.
- RVSM (without non-MASPS traffic) compared to CVSM resulted in a decrease in average workload in the RVSM exercises, with no significant difference between the Single and the Double FLOS **(see Figures 12/13)**.
- RVSM (with 1% non-MASPS traffic) compared to CVSM showed a lower workload with RVSM, with no difference between the FLOSs (this result was based on data taken from only one exercise run in the Single and Double FLOS).
- RVSM (with 3% non-MASPS traffic) compared to CVSM showed no significant difference in workload (the same result for the +35% **see Figure 20** and +55% exercises,)
- RVSM at +55% traffic with 0% non-MASPS had a similar average workload level to CVSM at +35% traffic **(see Figure 17)**.
- RVSM at +55% traffic with 3% non-MASPS had a significantly higher average workload level to CVSM at +35% traffic **(see Figure 23)**.

These results have indicated certain trends within the S08 Simulation environment, they are not necessarily globally representative and further studies are recommended in order to fully validate them.



#### 4.3.10 Analysis of RFL

Taking into account the whole airspace, there was no difference between the 3 FLOSs. About 80% of the aircraft reached their RFL.

The table below shows for each FLOS the percentage of aircraft which reached their RFL. The table also shows the number of flights which passed through each sector during the +55% traffic exercises.

Sector name	FLOS	Number of Aircraft			% of Aircraft		
		Total during measured hour	Mean	Max.	CFL=RFL	CFL<RFL	CFL>RFL
GE4	C	60	12	19	46	54	0
GE4	D	59	12	17	46	54	0
GE4	S	62	12	19	58	42	0
GE6	C	52	11	17	82	13	6
GE6	D	53	11	17	81	12	6
GE6	S	53	11	17	71	22	6
MIL	C	11	4	5	88	12	0
MIL	D	11	4	5	89	11	0
MIL	S	11	3	5	89	11	0
SOL	C	69	9	15	56	44	0
SOL	D	68	9	15	59	41	0
SOL	S	68	9	14	61	39	0
TAN	C	67	9	13	70	28	2
TAN	D	68	8	13	70	27	3
TAN	S	67	8	14	72	25	3
UE	C	65	10	17	65	35	0
UE	D	65	9	17	65	35	0
UE	S	65	10	18	65	35	0
UF	C	54	7	13	48	52	1
UF	D	57	7	15	44	55	1
UF	S	57	7	14	46	52	2
UH	C	68	9	16	66	32	2
UH	D	70	9	15	65	33	2
UH	S	68	8	12	66	31	3
ZU2	C	63	10	18	34	66	0
ZU2	D	59	9	17	37	63	0
ZU2	S	65	11	17	50	50	0
ZU3	C	58	10	15	81	13	6
ZU3	D	62	10	16	79	16	5
ZU3	S	54	9	16	75	19	6

In the +55% (1% non-MASPS) exercises each traffic sample had a total of 4 non-MASPS aircraft. The following list details the actions given to the non-MASPS traffic.

- 1 was descended to FL290.
- 1 did not reach it's RFL.
- 3 reached their RFL but 1 did not remain at it. Of the 2 that reached their RFL and kept it one had a lot of problems before reaching it. (Started at FL200, then to FL 340, then went back to FL290, then to FL 270 and then to FL360 and finally FL370 the RFL.)
- 1 was climbed from FL390 to FL400.
- 1 was descended from FL310 to FL300.



Even if only two exercises were run at +55% with 1% non-MASPS aircraft it can be seen that the controllers had difficulties integrating them in RVSM airspace.

In the +55% (3% non-MASPS) Single FLOS exercises, of 30 non-MASPS aircraft only 4 (13%) did not reach their RFL. However 24 of these aircraft started at their RFL and only 7 of them kept it until the end.

In the Double FLOS of 60 non-MASPS aircraft 11 (18%) did not reach their RFL. 40 of these aircraft start at their RFL and 14 of them kept it until the end.



#### 4.4 SPECIFIC OBJECTIVE 3

To validate the proposed general ATC procedures as developed by the APDSG (including ATC procedures to accommodate non-MASPS State Aircraft) required for RVSM implementation using the Double FLOS.

Note : Due to the results of Objective 1 the Single FLOS was compared in Objective 3.

##### 4.4.1 Results of non-MASPS aircraft operations

###### Integration of non-MASPS aircraft

At the beginning of the simulation it was estimated that the number of non-MASPS certified aircraft likely to be using the chosen airspace when RVSM implementation is proposed would be about 3% of the total traffic. This generally meant that between two to four aircraft passed through each sector during the measured hour. The number of non-MASPS aircraft was adjusted to 1% towards the end of the simulation in order to evaluate controller workload with a reduced amount of non-MASPS traffic.

The controllers found that the +35% traffic level (described by the controllers as similar to a busy summers day) plus 3% non-MASPS was very difficult to handle and many endeavoured to accommodate the non-MASPS traffic whilst working close to their capacity.

All of the controllers found that the non-MASPS traffic was difficult to integrate with RVSM traffic, the main reason being that the non-MASPS aircraft blocked three flights levels, the cruising level and the level immediately above and below. This meant that controllers were having to apply two different rules for separating aircraft within the same airspace.

On several occasions CVSM exercises were played after RVSM exercises. The controllers found very little difficulty returning to CVSM exercises as they were using their normal operating procedures and many expressed relief at not having to deal with aircraft that required special handling (non-MASPS).

***Q. Did the integration of non-MASPS aircraft reduce the advantage of the additional RVSM levels.***

YES	=100%
NO	= 0%

***If YES, by how much ?***

A little	= 6%
Moderately	= 11%
A lot	= 66%
Completely outweighed the RVSM advantages	= 17%



When the traffic was increased to +55% with 3% non-MASPS the controllers were working very close to capacity and some of them resorted to descending the non-MASPS below FL290 in order to reduce their workload. During the exercises where all GAT was played as MASPS certified, all the controllers considered the absence of the non-MASPS traffic helped them in their controlling task and appreciation of RVSM. Although the traffic sample was still very busy the fact that there was no need to look out for or plan to accommodate the non-MASPS made their controlling task much easier.

**Q. Do you consider that the exercises with no non-MASPS aircraft helped you to appreciate the difference between CVSM and RVSM ?**

YES	= 75%
NO	= 15%
Not Sure	= 10%

**Q. Do you consider that the exercises with no non-MASPS aircraft helped you to appreciate the difference between the Single FLOS and Double FLOS ?**

YES	= 45%
NO	= 30%
Not Sure	= 25%

For the +65% traffic samples the amount of non-MASPS aircraft was reduced to 1% (equating to about 1 non-MASPS aircraft passing through each sector during the measured hour). The majority of controllers felt that they were working at their limit with the +65% level of traffic, and because of this several of the non-MASPS flights were descended or climbed to levels where they would not cause problems to the controller. The non-MASPS aircraft which remained at their RFL often did so because there were no conflicts within the traffic situation.

Many controllers felt they were only able to manage the traffic because the aircraft were responding immediately to commands, opposed to real life where a blocked frequency or slow response would make the situation unmanageable and dangerous.

**Q. Do you consider the presence of non-MASPS aircraft within your sector affects**

The service provided to MASPS certified aircraft

YES	=100%
NO	= 0%

The safety of other aircraft

YES	= 89%
NO	= 11%



**Q. Which aircraft were penalised because of the requirement to integrate non-MASPS aircraft into the exercises ?**

Non-MASPS	= 10%
MASPS	= 35%
Both types were equally penalised	= 55%

**Non-MASPS operating close to the sector division FL345**

The sectors which were split at FL345 (Geneva and Zurich) raised the problem of non-MASPS traffic flying at a cruising Flight Level within 1000 feet of the sector division (**see Figure 24**). As it is not normal to see the traffic below or above your own sector (unless you change the height filter) this proved to be potentially very dangerous as the non-MASPS require 2000 feet separation and the controllers were required to co-ordinate with the sector above/below to make sure there was no conflicting traffic concealed in the sector above or below. This situation exists in the Single and Double FLOS.

This was also a problem with adjacent sectors who were controlling the non-MASPS traffic prior to entering the Geneva and Zurich areas and were confused with who had the responsibility for separating the aircraft. As a result all the sectors concerned were potentially having to increase their workload to ensure the safe passage of the non-MASPS traffic.

The Swiss controllers suggested blocking FL340 and FL350 for use by non-MASPS traffic (unless prior co-ordination is agreed) and where possible the adjacent sectors would arrange the traffic before it entered the Geneva and Zurich areas at Flight levels which would only concern one sector. This procedure was adopted after the first week and generally worked well, helping to reduce the confusion and workload between upper and lower sectors and adjacent ATCCs.

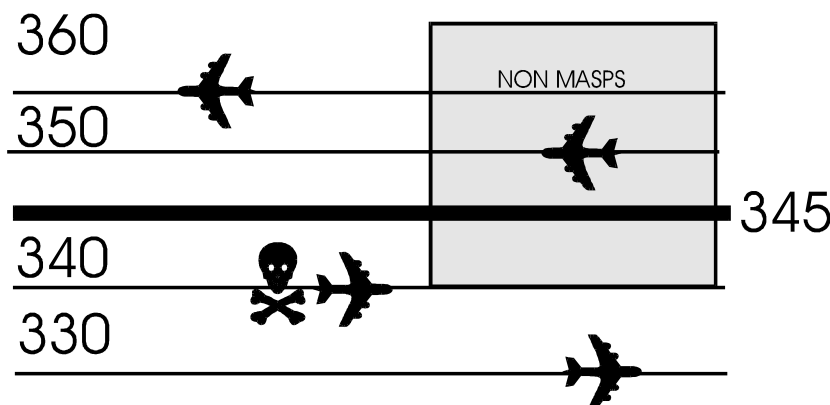

**Figure 24 - Example of a non-MASPS aircraft flying close to the sector division.**





### Pre-notification of non-MASPS flights

Many of the controllers felt that in the future non-MASPS aircraft which are planned to fly through their sector would require more notice than the 8 minutes warning given in the simulation environment. A procedure was tested during the simulation, where controllers would notify the next sector by landline of the non-MASPS flight as soon as considered necessary.

The co-ordination of non-MASPS traffic between sectors using a telephone line generally worked well. It was however felt that this should only be necessary between ATCCs as internal sectors normally have the same radar display and strip information and therefore should have the correct data regarding the non-MASPS status. The landline call would therefore be used to verify that the correct flight plan data had been sent to the next ATCC.

#### ***Q. Do you consider that there is a requirement for additional co-ordination or handover procedures for non-MASPS aircraft ?***

YES	= 39%
NO	= 56%
Not Sure	= 5%

#### **4.4.2 Proposed general ATC procedures as developed by the APDSG**

Paper Flight strips for all non-MASPS certified aircraft with an RFL between FL240 and FL430 inclusive, are to include a highlighted notation of the phrase “**Non-RVSM**”. Flight strips for State aircraft within this group are to include an additional highlighted notation of “**State aircraft**”.

Radar labels for those aircraft non-MASPS compliant aircraft operating within the level bands FL240 to FL430 inclusive, are to be distinguished, to the extent the display systems make possible, preferably through the use of colour

Pilots of State Aircraft non-MASPS compliant operating as GAT shall include the phrase “**NON-RVSM**” on initial call on any frequency within the RVSM airspace.

Controllers will readback the message.

Pilots of State Aircraft non-MASPS compliant operating as GAT shall include the phrase “**NON-RVSM**” to all requests for flight level changes within the RVSM airspace.

Pilots of State Aircraft non-MASPS compliant operating as GAT shall include the phrase “**NON-RVSM**” to the read back of all clearances pertaining to a Flight Level change within the RVSM airspace.



4.4.3 Results of study using a coloured Radar Label

In order that the controllers were able to visually discern Non-MASPS compliant State aircraft from others, for the purpose of either establishing the requirement for a 2,000 ft vertical separation in the RVSM airspace or as a means of minimising the risk of inadvertently clearing non-MASPS compliant Non-State aircraft into the RVSM airspace the radar label was coloured **GREEN**. All MASPS compliant aircraft had **YELLOW** labels and the Military OAT labels were coloured **WHITE** (see Figure 25 )

All of the controllers found that the green radar label used to highlight the non-MASPS aircraft was effective, and because of this the use of 'NON-RVSM' in the R/T procedures was a useful reminder but deemed not as effective as the coloured radar label.

**Q. Was the use of the Green label to identify the non-MASPS aircraft on the radar screen**

Necessary = 100%  
 Not Necessary = 0%

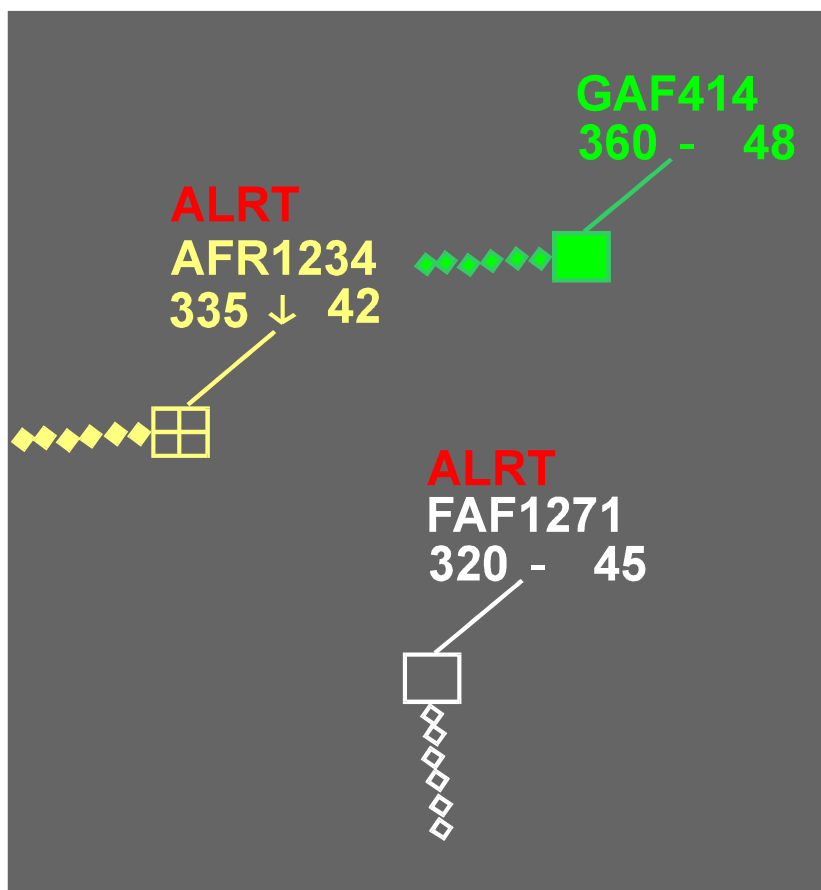

Figure 25 - Example of the different colours used for Radar Labels



4.4.4 Results of study on Flight Strips

In order that the controllers were able to visually discern non-MASPS compliant Non-State aircraft from others, the notation “**Non-RVSM**” was printed in the bottom left hand corner of the flight strip. For non-MASPS compliant State aircraft the notation “**Non-RVSM/S**” was used.

**Q. Was the printing of ‘Non-RVSM’ on the flight strip**

Necessary = 100%  
 Not Necessary = 0%

**Q. Did the addition of ‘S’ after the words ‘Non-RVSM’ sufficiently highlight to you the fact that the aircraft was a Non-MASPS ‘STATE aircraft’ ?**

YES = 56%  
 NO = 33%  
 Not Sure = 11%

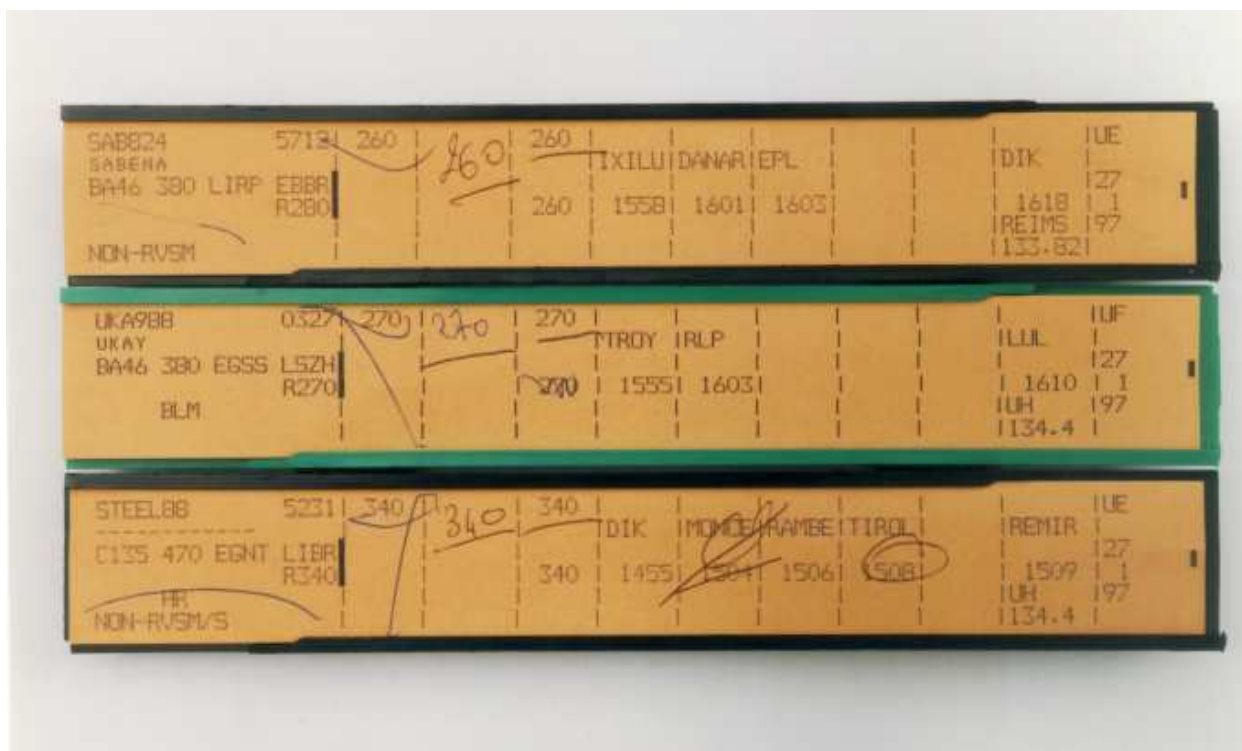

Figure 26 - Example of Flight Strips



The use of a different colour flight strip holder was also tested to highlight the non-MASPS status to the controller. The majority of controllers felt that a different colour strip holder was necessary to highlight the non-MASPS aircraft, but where different colours are used to indicate to the controller the direction of a flight this caused a potential problem. This could possibly be overcome with dual coloured strip holders.

**Q. Do you consider the use of a different colour strip holder to highlight the non-MASPS aircraft**

Necessary = 78%  
 Not Necessary = 22%

In **Figure 27**, the non-MASPS traffic are in RED coloured strip holders, with the BLUE and YELLOW holders being used to indicate direction of flight i.e. northbound/southbound.

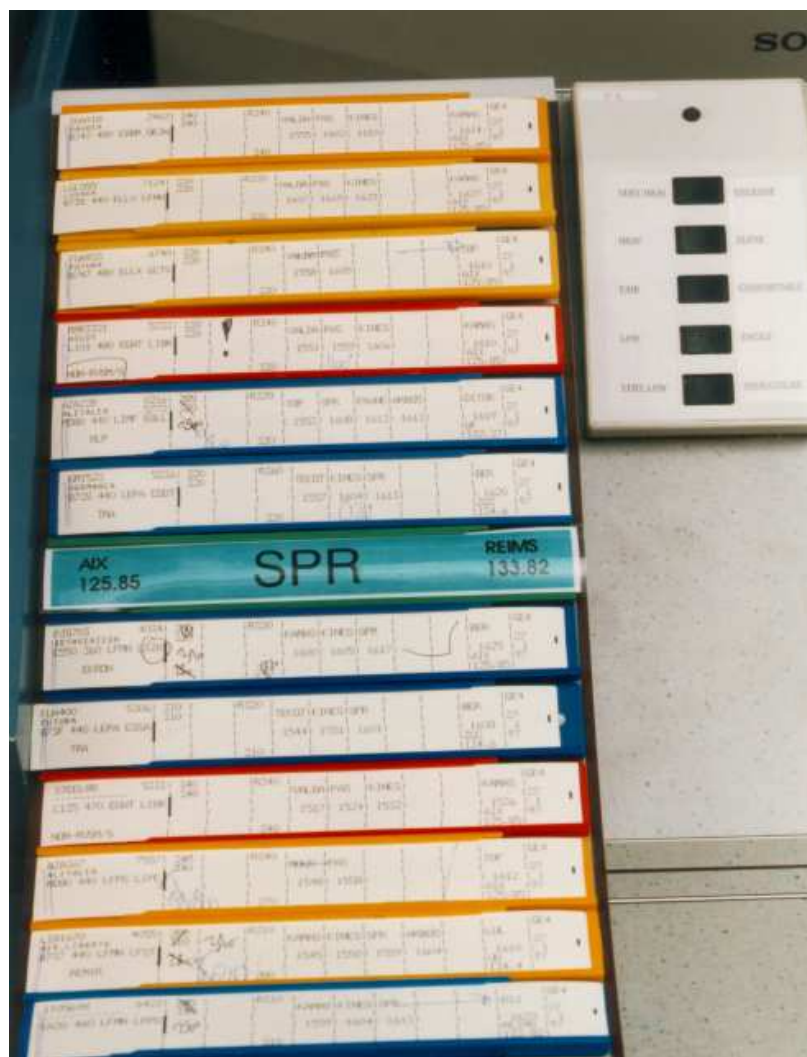

**Figure 27 - Strip bay showing the effect of different colour strip holders**



#### 4.4.5 Result of study on Phraseology

The controllers considered that some of the new R/T procedures were useful and served as a good reminder to supplement the coloured label and the flight strip warning. However some felt that the procedures should be modified to reduce the workload created by the changes and it was agreed to acknowledge the non-RVSM aircraft only on the first call (similar to the R/T used for heavy aircraft i.e. DLH4432 Heavy).

**Q. Is the phrase 'Non-RVSM' sufficient to indicate to you that the aircraft is non-MASPS certified ?**

YES = 100%  
NO = 0%

**Q. Do you consider that the phraseology 'Non-RVSM' should be used by the pilot on first contact with the sector ?**

YES = 100%  
NO = 0%

**Q. Do you consider it necessary for the controller to readback the phrase 'Non-RVSM' when the pilot first contacts the sector ?**

YES = 39%  
NO = 61%

**Q. Do you consider it necessary for the pilot to include the phrase 'Non-RVSM' for every flight level change ?**

YES = 11%  
NO = 89%



#### 4.5 SPECIFIC OBJECTIVE 4

To validate the proposed ATC contingency procedures based upon pre-described ATC contingency situations.

##### 4.5.1 Contingency procedures for individual aircraft

As a consequence of a pilot reporting that he/she is no longer able to maintain altitude in accordance with RVSM as a result of an **equipment related contingency** (i.e. aircraft becomes Non-MASPS compliant), the controller will:

- as soon as practicable, provide for an increased vertical separation of 2,000 ft or an appropriate lateral radar separation.
- as soon as practicable, clear the aircraft to a level outside the RVSM airspace.
- manipulate the radar label to distinguish it from other MASPS compliant aircraft.
- co-ordinate the circumstances to the adjacent sector/centre concerned.

As a consequence of a pilot reporting that he/she is no longer able to maintain altitude in accordance with RVSM as a result of a **weather related contingency**, the controller will:

- as soon as practicable, provide for an increased vertical separation of 2,000 ft or an appropriate lateral radar separation.
- accommodate requests for level changes to the extent possible.
- solicit turbulence reports from other aircraft in the vicinity.
- manipulate the radar label to distinguish it from other MASPS compliant aircraft.
- co-ordinate the circumstances to the adjacent sector/centre concerned.

##### 4.5.2 Contingency procedures for multiple aircraft (weather related contingency)

For the case where the **weather phenomena is not predicted**, controllers will:

- as soon as practicable, provide for a 2,000 ft vertical separation or an appropriate lateral radar separation to the aircraft effected.
- establish traffic at levels in use today (i.e., FLs 310, 330, 350, etc.), prior to the transfer at control points.
- co-ordinate any new levels with adjacent sectors/centres.
- inform supervisory staff.

supervisors will :

- determine the extent to which all or any part of the RVSM airspace under their authority should revert to a 2,000 ft vertical separation minimum.
- co-ordinate with adjacent centres, informing them that traffic can only be accepted at the levels currently in use today (i.e., FLs 310, 330, 350, etc.).



#### 4.5.3 Results

Two exercises (+55% Double FLOS) were played which involved contingency procedures. Due to time constraints only the Double FLOS was simulated.

The first exercise simulated individual aircraft declaring that they were “**Unable RVSM due Equipment**”. Each sector was given 1 aircraft with such a condition to handle. The majority of controllers correctly descended the aircraft below FL290, most of the aircraft received vectors to enable their descent and some of the MASPS traffic was also vectored to allow the problem aircraft to descend. Some controllers descended the aircraft to provide the required 2000’ separation however the aircraft was not descended below FL290 because the traffic situation was very complex. One aircraft (a Frankfurt inbound ) was given descent earlier than normal but an immediate descent below FL290 was considered not appropriate due to the traffic situation.

Several controllers considered that there would need to be a requirement to change the colour of the radar label if an aircraft becomes non-RVSM to act as a constant reminder to the controller.

The second exercise simulated a build up of turbulence over the Alps (**Unable RVSM due to Turbulence**). This resulted in the two Zurich and the two Geneva sectors having to revert to CVSM and apply 2000’ separation within their sectors and the adjacent sectors having to hand over traffic at CVSM levels. All the controllers agreed that they had no problem reverting to the CVSM levels from the Double FLOS and then changing back to the Double FLOS when the turbulence had passed. Many commented on the fact that adjacent airspace (especially Military areas) is often used during situations like this to achieve the required lateral separation if vertical separation is not possible.



#### 4.6 SPECIFIC OBJECTIVE 5

**To determine the operational impact of a new vertical sector division FL345 within the Reims sectors UE and UH using the double FLOS.**

**Note : Due to the results of Objective 1 the Single Alternate FLOS was also compared in Objective 5.**

##### 4.6.1 Organisation 2 - Reims re-sectorisation

A sector split of FL345 was introduced in the current UE and UH French sectors. The new lower sectors were named AE and AH and the Upper sector above AE and AH was named YE. The current UF sector became part of the Reims Feed sector.

The traffic samples used were +65% with 1% non-MASPS.

A map showing the re-sectorisation can be seen in Annex A.

##### 4.6.2 Results

The main difficulty the French controllers experienced was the increased co-ordination between the upper and lower sectors, a problem caused by the lack of previously agreed ATC procedures for climbing and descending traffic. The overall workload of the controller was reduced by the sectorisation split but the planner had to anticipate situations more than in Organisation1 because of the extra co-ordination required with the new division.

The majority of the Reims controllers still preferred to use the Single FLOS especially in the planning position, due to the logical distribution of levels and the fact that they have many uni-directional routes where they can use 1000' to climb or descend traffic to solve conflicts, however one or two preferred either the Double FLOS or had no preference for either FLOS.

The French Military controllers saw little change to their operations with the new sectorisation and showed no preference for either FLOS.

The level chosen to split the sectors (FL345) caused some difficulties, for example :  
In the Double FLOS the Paris inbound traffic at FL350 (Even) on the route HOC-MOROK requires to be handed to Paris at ODD levels, FL330/340. If the level change is done whilst in sector YE then the profile normally enters sector AH adding more workload to that sector. This is also a problem in the SINGLE FLOS when the traffic comes in at FL340/360 and requires to be at FL330/350. Therefore if RVSM was introduced with this sectorisation the flight level division / procedures should be carefully studied at the same time that letters of agreement are reviewed.





## 5. CONCLUSIONS

The following conclusions can be made regarding the specific objectives

### 1. To further evaluate the operational advantages and disadvantages associated with the strategic use of RVSM in the Single and Double FLOS against the CVSM reference.

The Single and Double FLOS offered operational advantages compared to CVSM with the only disadvantages being lack of familiarity, the presence of non-MASPS certified aircraft and the need for some revised procedures. The main advantage to the controller was gaining the use of six extra flight levels. All the controllers were in favour of RVSM, and when asked at the end of the simulation to indicate a preference towards a FLOS (Single or Double) many were hesitant as they felt they could operate in either situation given adequate training and procedures. The final result showed no clear preference to either FLOS.

The Military controllers also showed no preference for either FLOS. They considered that to safely operate OAT within an RVSM environment it would be essential to be able to coordinate directly with the civil controllers and to have a radar system which was able to give information on the flight level intentions of the civil traffic.

### 2. To compare the controller workload and sector throughput between the RVSM reference traffic samples and 2 traffic samples with a higher traffic level using the Double Alternate FLOS. (Due to the results in objective 1 the Single FLOS was also studied in this objective)

There was no significant difference in controller workload between the Single and the Double FLOS regardless of the traffic level. The presence of non-MASPS aircraft increased controller workload when compared to a totally MASPS environment. There was little difference in controller workload figures when CVSM was compared to RVSM with 3% non-MASPS traffic using the same traffic load.

There was a decrease in controller workload in RVSM exercises when all traffic was MASPS certified compared to the same traffic using CVSM.

RVSM at +55% traffic (0% non-MASPS) showed a similar average controller workload level to CVSM at +35% traffic. It should however be noted that although this could indicate up to a 20% increase in sector throughput, the analysis was made on only 3 repetitions of the traffic samples and the +55% runs were played during week three of the simulation when the controllers were more familiar with the traffic samples. Therefore further study is recommended to validate the results.

The traffic samples with the increased traffic levels created a very high R/T load. There was a noticeable reduction in the total number of R/T orders when RVSM was used, but no significant difference between the Single and Double FLOS. There was a significant reduction in the number of headings issued in RVSM exercises compared to CVSM ( this reduction was more noticeable with the absence of non-MASPS traffic).



- 3. To validate the proposed general ATC procedures as developed by the ATM Procedures Development Sub-Group (including ATC procedures to accommodate Non-MASPS State Aircraft ) required for RVSM implementation using the Double FLOS. (Due to the results in objective 1 the Single FLOS was also studied in this objective)**

#### **Non-MASPS**

The integration of non-MASPS certified traffic within RVSM airspace caused many problems in particular they affected safety and reduced the benefits of RVSM. The majority of non-MASPS traffic received either radar vectors or a change in flight level and the service to MASPS aircraft was affected.

**The controllers used 3 methods to help them to identify the non-MASPS certified traffic.**

**Radar label** - All the controllers used a Sony screen with colour display. The green radar label used to highlight the non-MASPS traffic was very effective and all controllers considered it necessary.

**Flight Strip** - The controllers considered the printing of the words 'Non-RVSM' on the flight strip necessary, and many used a different colour strip holder as an additional reminder.

**Phraseology** - The controllers considered that the proposed R/T phraseology was excessive and took up too much R/T time. It was agreed to modify the procedures for the simulation and all the controllers considered that the phrase "Non-RVSM" was sufficient to indicate the aircraft's certification and that the phrase should be used on first contact with a sector. Most of the controllers did not consider it necessary to use the phrase every time a level change was requested.

- 4. To validate the proposed ATC contingency procedures based upon pre-described ATC contingency situations.**

The change from RVSM to CVSM to RVSM was handled with few comments and when there was no level available controllers vectored the traffic into adjacent airspace (i.e. military areas) following co-ordination, a practice which they often use in real life controlling. Where single aircraft were unable to conform to RVSM due to equipment failure the majority were correctly descended below FL290 as briefed. The controllers did feel that there should be the capability to change the colour of the radar label to indicate the non-MASPS status of the aircraft following an equipment failure.

- 5. To determine the operational impact of a new vertical sector division FL345 within the Reims sectors UE and UH using the Double FLOS.**

The overall workload was reduced by the sector split at FL345, however, due to the lack of previously agreed procedures, there was an increase in co-ordination between the upper and lower sectors. There was some concern about the level used to split the sectors as this affected the procedures used for Paris inbound traffic.



## 6. RECOMMENDATIONS

- The decision on which FLOS to use within ECAC airspace is made as soon as possible to allow RVSM implementation to commence and at the same time a FLAS should be considered to enable a more orderly flow of traffic across Europe, especially at major cross over points.
- The simulation identified that non-MASPS GAT traffic increased controller workload appreciably. It is therefore recommended that the number of non-MASPS GAT aircraft within RVSM airspace be kept to a minimum. Further study should be carried out using a smaller number of non-MASPS GAT (1% or 2%) to confirm the effects on controller workload and safety.
- The effect of Vortex Wake turbulence within an RVSM environment is investigated.
- The simulation proved that some new R/T phraseology, coloured radar labels and specific flight strip marking all helped to highlight to the controller the non-MASPS traffic. Therefore in the interests of safety, it is recommended that these procedures are introduced for non-MASPS traffic operating within RVSM airspace.
- Procedures for contingency situations should be simulated when a FLOS has been chosen and using scenarios based upon real life occurrences.



Intentionally left blank



### TRADUCTION EN LANGUE FRANÇAISE DU RESUME

#### RESUME

La simulation temps-réel S08 était la troisième simulation RVSM (Reduced Vertical Separation Minima) continentale conduite au Centre Expérimental EUROCONTROL (EEC) à Brétigny, France. La première simulation a étudié l'utilisation du « Single Alternate » FLOS à l'intérieur de l'espace aérien de la France et de la Suisse. La seconde simulation a étudié le « Single Alternate » et le « Double Alternate » FLOS à l'intérieur de l'espace aérien de la Hongrie.

Les résultats des deux premières simulations ont montré que la disponibilité de six niveaux supplémentaires avec RVSM offrait de nombreux avantages opérationnels. Le but de la troisième simulation était de continuer l'étude de ces bénéfices dans un environnement multi-ATCC en Europe centrale.

Des contrôleurs civils de quatre centres de contrôles du trafic aérien (Reims-France, Karlsruhe-Allemagne, Genève et Zurich - Suisse) et des contrôleurs militaires du CDC de Lyon ont pris part à cette simulation en utilisant la même IHM (Interface Homme Machine) sans modification des secteurs ou des réseaux de routes pour la majeure partie de la simulation. Trois différents niveaux d'échantillon trafic (1996+35%, +55% et +65%) ont été utilisés pour étudier l'impact de RVSM sur la charge de travail des contrôleurs.

L'idée initiale était d'étudier le FLOS « Double Alternate » puisqu'il était le FLOS préféré des contrôleurs pendant la seconde simulation RVSM continentale. Pour valider cette préférence, des exercices au niveau de trafic +35% ont été joués avec les deux FLOS. Après 8 jours de simulation, 10 contrôleurs préféraient le « Single » FLOS, 5 préféraient le « Double » FLOS et 5 avaient encore besoin de temps pour se décider. Il a alors été décidé de continuer d'examiner les deux FLOS pour le reste de la simulation.

Pendant la simulation les contrôleurs se sont rapidement habitués à l'utilisation des niveaux RVSM quelque soit le FLOS et étaient d'accord pour que ces niveaux soient introduits aussitôt que possible. La plupart des contrôleurs ont considéré que les deux FLOS pouvaient indifféremment être utilisés dans leur espace à condition que les procédures ATC; lettres d'accord; sectorisations et réseaux de routes soient revus et adaptés.

Les résultats de la simulation montrent qu'il n'y a aucune différence significative en terme de charge de travail entre le « Single » et « Double » FLOS. Il n'y avait aucune différence sensible entre le « Single » et le « Double » FLOS, et beaucoup d'avantages ou d'inconvénients pouvaient indifféremment s'appliquer à l'un ou l'autre FLOS, suivant la dimension et la forme de l'espace concerné.

En comparant RVSM (sans trafic non-MASPS) à CVSM, nous avons constaté une réduction significative de la charge de travail du contrôleur. Cependant, l'introduction d'avions non-MASPS a accru la charge de travail des contrôleurs et réduit considérablement les bénéfices de RVSM. Les contrôleurs ont trouvé qu'il était très difficile d'intégrer du trafic non-MASPS car cela signifiait qu'ils devaient assurer deux séparations standards à l'intérieur du même espace



L'espace simulé comportait de nombreux points de croisements congestionnés. Bien qu'aucun FLAS (Flight Level Allocation System) n'ait été étudié durant cette simulation, il est recommandé que les futures simulations examinent l'application et les bénéfices potentiels d'un FLAS qui pourrait être utilisé quelque soit le FLOS et pourrait aider à résoudre les nombreux problèmes rencontrés par les contrôleurs quand des flux de trafic provenant de plusieurs directions se croisent.

### **RVSM : LE CONTEXTE**

En 1960, l'ICAO a choisi d'établir une séparation verticale minimale de 1000 pieds en dessous du niveau 290 et de 2000 pieds au-delà. Cette limite verticale a été fixée en fonction de la précision des altimètres barométriques utilisés à cette époque.

Dans le cadre du programme EATCHIP, le groupe ANT (Airspace and Navigation Team) a sponsorisé des simulations temps-réel et des simulations par modèles dans l'optique de l'implémentation de la RVSM. Plusieurs de ces études ont été assurées sous la direction du Centre Expérimental EUROCONTROL (CEE).

En mai 1994, le CEE a conduit une simulation temps-réel AR37 NAT-RVSM (rapport CEE N° 284). Cette simulation a étudié les procédures qui seront nécessaires à l'intérieure des zones de transitions RVSM lorsque la RVSM sera introduite dans la région NAT.

La 1ère simulation temps-réel de la RVSM continentale, AS16 Reims, a été achevée en mai 1995 (rapport CEE N° 294). Cette simulation avait été conçue pour analyser l'impact opérationnel associé à l'introduction de la RVSM sur l'Europe Continentale. Dans cette simulation, les espaces supérieurs de la France, de l'Allemagne et de la Suisse ont été simulés avec l'hypothèse que tous les avions étaient certifiés MASPS.

La 2ème simulation temps-réel de la RVSM continentale, SA4 Hongrie, a été achevée en juin 1996 (rapport CEE N° 309). Cette simulation a évalué les avantages et désavantages opérationnels associés aux FLOS « Single Alternate » et « Double Alternate ». L'allocation des niveaux de vol a été étudiée de façon tactique et stratégique et des avions Non-MASPS étaient inclus dans les trafics.

Le 27 mars 1997 RVSM a été introduit dans la région de l'Atlantique Nord (NAT), entre les niveaux de vol 330 et 370, dans l'espace MNPS (Minimum Navigation Performance Specification). Les niveaux de vol sont alloués selon le flux de trafic prédominant (Est ou Ouest).

La décision d'implémentation de la RVSM dans l'espace ECAC a été décidée par le groupe ANT en juin 1997. La « RVSM Task Force » recommandera un FLOS au groupe ANT en octobre 1997 et la décision finale sur le choix du FLOS sera faite par le groupe ANT en décembre 1997. L'implémentation de la RVSM est prévue pour 2001.



## DÉFINITIONS

### Conventional Vertical Separation Minima (CVSM)

CVSM est la séparation standard actuellement appliquée dans laquelle les niveaux de vol au-dessus de 290 pieds sont séparés de 2000 pieds.

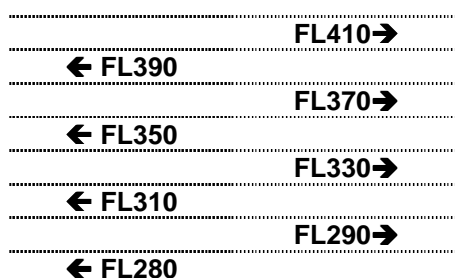

Figure 27 - CVSM Flight levels

### Reduced Vertical Separation Minima (RVSM)

RVSM est un concept approuvé par l'ICAO pour réduire la séparation verticale de 2000 pieds à 1000 pieds, entre les niveaux de vol (FLs) 290 et 410 inclus. Deux Schémas d'orientation des niveaux de vol (FLOS ou Flight Level Orientation Schemes) ont été proposés pour l'implémentation de la RVSM lors d'une conférence de l'ECAC (European Civil Aviation Conference), le FLOS « Single Alternate » et le FLOS « Double Alternate ».



### Single Alternate Flight Level Orientation Scheme

Le FLOS « Single Alternate » est représenté sur la figure ci-dessous. La séparation standard de 1000 pieds est étendue jusqu'au niveau de vol 410 en conservant la convention : Les niveaux pairs sont orientés Ouest et les niveaux impairs sont orientés Est. On remarquera que les niveaux de vol 310, 350 et 390 actuellement orientés Ouest sont alors orientés Est.

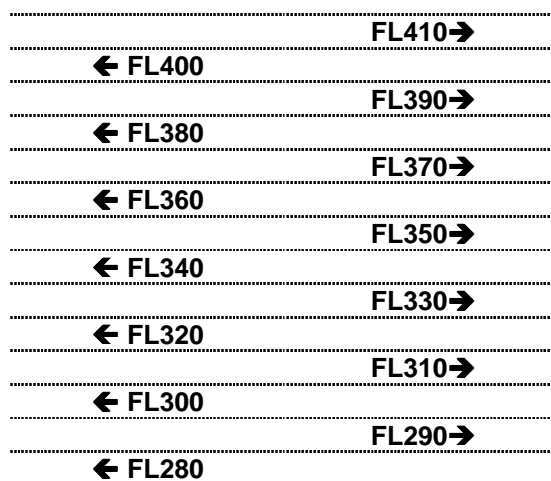

Figure 28 - Single Alternate FLOS

### Double Alternate Flight Level Orientation Scheme

Le FLOS « Double Alternate » est représenté sur la figure ci-dessous. Dans ce FLOS l'orientation des niveaux actuels est conservée et chaque niveau conventionnel est complété par un niveau RVSM immédiatement supérieur de même orientation.

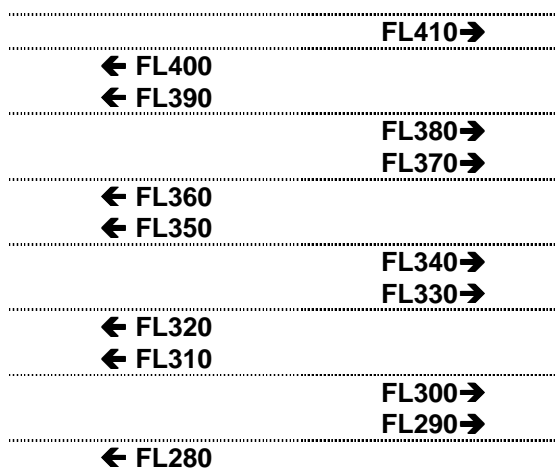

Figure 29 - Double Alternate FLOS





### **MASPS and Non-MASPS**

MASPS (Minimum Aircraft System Performance Specification) est la certification à laquelle un avion doit être conforme pour pouvoir opérer dans un espace RVSM. La majorité des avions civils modernes sont conformes à MASPS mais certains avions, plus anciens, devront être équipés à cette fin. Après l'introduction de RVSM en Europe continentale, il est donc prévu de continuer à assurer des séparations CVSM à un petit nombre d'avions comme les avions d'Etat. L'équipement nécessaire à la certification MASPS se compose d'au moins deux systèmes de mesure de l'altitude, un radar SSR, un système d'alerte d'altitude, et un système de contrôle automatique de l'altitude. **Non-MASPS** est le terme utilisé pour un avion qui n'est pas certifié MASPS.

### **State and Non-State Aircraft**

Un « State Aircraft » ou Avion d'Etat est un avion qui est sous la responsabilité des Militaires, de la Police ou de la Douane. Tous les autres avions sont classés comme « Non-State Aircraft ».



### **SIMULATION TEMPS REEL S08 RVSM CONTINENTALE**

La 3ème simulation temps-réel RVSM continentale d'EUROCONTROL (Tâche CEE S08) s'est déroulée au Centre Expérimental EUROCONTROL, Brétigny-sur-Orge, entre le 20 janvier et le 14 février 1997. Elle a poursuivi l'analyse des FLOS « Single et Double Alternate » dans le cadre de l'utilisation de la RVSM entre les niveaux de vol 290 et 410. La simulation a analysé aussi l'intégration et les procédures pour les avions non certifiés MASPS tout en tenant compte des recommandations faites lors de la 2ème simulation EUROCONTROL RVSM continentale, SA4 Hongrie (rapport CEE N°309).

#### **Objectifs generaux**

1. Obtenir de nouveaux résultats concernant la comparaison entre les FLOS « Single et Double Alternate » dans le cadre d'un environnement multi-ATC en Europe centrale.
2. Confirmer la pertinence du FLOS « Double Alternate » (comme recommandée par la « RVSM Task Force » ainsi que par les précédentes simulations RVSM) dans le cadre d'un environnement multi-ATC en Europe centrale.
3. De quantifier les bénéfices de la RVSM pour l'ATM (Air Traffic Management) dans l'espace ECAC.

#### **Objectifs particuliers**

Les objectifs spécifiques sont détaillés dans la CONCLUSION.

### **ENVIRONNEMENT DE LA SIMULATION**

L'objectif était de fournir une plate-forme opérationnelle commune à tous les ATCCs participants à la simulation qui soit à la fois facile à utiliser et nécessite une période d'adaptation minimale. Tous les secteurs ont utilisé le même équipement radar et les mêmes fonctionnalités, avec les données de vol affichées sur des « Strip » papiers..

#### **Organisations**

Deux organisations étaient utilisées durant la simulation. La majorité des exercices ont été joués avec l'Organisation 1 qui reprenait la sectorisation et le réseau de route utilisé en novembre 1996. L'Organisation 2 simulait une coupure au niveau 345 des secteurs UE et UF de Reims, le secteur UF étant intégré au secteur Feed de Reims.



### **Le MCS (Multi-aircraft Cockpit Simulator)**

Le MCS est une position pilote sophistiquée développée au CEE qui permet la participation de pilotes professionnels dans les simulations ATC temps-réel. Le MCS a été utilisé durant la simulation et fonctionnait en conjonction avec les stations pseudo-pilotes. Durant la simulation quelques pilotes professionnels ont « volé » avec le MCS. Cependant, la plupart du temps, il a été utilisé par du personnel d'EUROCONTROL et les commentaires des pilotes professionnels sur les problèmes liés à RVSM ont été considérés comme minime.

### **ECHANTILLONS DE TRAFIC**

#### **La création des échantillons de trafic**

Les trafics CVSM ont été créés au Centre Expérimental EUROCONTROL. Ils étaient basés sur un trafic du matin et un trafic de l'après-midi enregistrés le jeudi 24 mai 1996 et fournis par les ATCC participants. Les échantillons ont été ajustés pour représenter une charge de travail équivalente aux capacités maximales des secteurs en 1996 augmentées de +35%, +55% et +65%. Pour les échantillons de trafics RVSM les niveaux de vols ont été ajustés en utilisant les règles proposées par la Division développement d'EATCHIP d'EUROCONTROL (DED4).

#### **Contraintes spécifiques**

Les contraintes suivantes ont été appliquées aux échantillons de trafic :

- Les échantillons de trafic RVSM incluaient des avions civils non-MASPS (non-MASPS non-State) et des avions d'Etat non-MASPS (non-MASPS State).
- Les avions civils non-MASPS étaient restreints aux niveaux de vol inférieurs ou égaux 290.
- Les avions d'Etat non-MASPS volaient comme des avions GAT (General Air Traffic) sur des routes civiles. Le 1% d'avions non-MASPS correspondait à environ 1 avion non-MASPS par secteur pendant l'heure mesurée. Les 3% d'avions non-MASPS correspondaient à environ 2 à 4 avions non-MASPS par secteur en fonction de la capacité du secteur.
- Le trafic militaire était contrôlé par les militaires français et représentait un trafic OAT normal (Operational Air Traffic) dans l'espace Est de la France.
- Tous les avions militaires OAT étaient considérés comme non-MASPS.

Au total 57 exercices ont été exécutés; 4 étaient des exercices de familiarisation; 2 étaient des exercices comprenant des turbulences et les 51 exercices restants étaient des exercices mesurés.



### PROCEDURES OPERATIONNELLES

#### Procédures ATC CVSM

Les procédures ATC utilisées durant la simulation étaient en accord avec les Lettres d'agrément et/ou des instructions opérationnelles particulières (à l'exception de la coordination Civils/Militaires française - voir ci-dessous).

#### Procédures ATC RVSM

Les avions certifiés MASPS opérant comme GAT à l'intérieur de l'espace RVSM étaient séparés verticalement de 1000 pieds ou par une séparation latérale.

Les avions d'Etat non-MASPS opérant comme un trafic GAT à l'intérieur de l'espace RVSM étaient assurés d'une séparation verticale minimum de 2000 pieds ou d'une séparation latérale

Les avions d'Etat non-MASPS opérant comme un trafic OAT à l'intérieur de l'espace RVSM étaient assurés d'une séparation verticale minimum de 2000 pieds ou d'une séparation latérale pour assurer la séparation entre les avions OAT et les avions GAT.

#### Les procédures de coordination entre Civils et Militaires français

***Les procédures suivantes ont été adoptées seulement pour la durée de la simulation.***

La prévention des collisions était toujours sous la responsabilité des contrôleurs militaires. Pendant les périodes de trafic dense, une requête de coordination pouvait être refusée soit par un contrôleur civil, soit par un contrôleur militaire.

Pour les avions militaires croisant des routes civiles, la coordination était initiée par le contrôleur militaire au moyen du téléphone. Le contrôleur militaire donnait la position et l'indicatif des avions civils et militaires et proposait la suite d'actions à entreprendre. Le contrôleur civil pouvait alors agréer ou suggérer une autre solution.

Un contrôleur civil pouvait demander une coordination pour entrer dans une zone militaire à condition de prévenir 2 minutes à l'avance et que ses intentions soient données au contrôleur militaire. Le contrôleur militaire pouvait alors agréer ou suggérer une autre solution.

#### Short Term Conflict Alert (STCA)

Le système de STCA était programmé pour déterminer la différence entre les différentes catégories d'avions entre les niveaux de vol FL290 et FL410 :

- Avions certifiés MASPS et autres avions certifiés MASPS.
- Avions certifiés MASPS et Non-MASPS.
- Avions non-MASPS et autres avions non-MASPS.



## RESULTATS (conclusions)

***L'ensemble détaillé des analyses et des résultats se trouve dans le rapport principal.***

Les conclusions suivantes peuvent être faites au regard des objectifs spécifiques.

### **1. De continuer à évaluer les avantages et désavantages opérationnels liés à l'utilisation stratégique de la RVSM « Single et Double Alternate » par rapport à la CVSM.**

Le « Single » et « Double » FLOS comparé à CVSM ont offert des avantages opérationnels avec pour seul inconvénient le manque de familiarisation, la présence d'avions non certifiés MASPS et le besoin de revoir certaines procédures. Le principal avantage pour les contrôleurs était la possibilité d'utiliser six niveaux de vols supplémentaires. Tous les contrôleurs étaient en faveur de la RVSM, et lorsqu'on leur a demandé, à la fin de la simulation, d'indiquer leur FLOS préféré nombreux étaient ceux qui hésitaient. Ils pensaient pouvoir opérer quel que soit le FLOS après une formation adéquate et de nouvelles procédures. Le résultat final ne montrait aucune préférence majeure pour l'un des FLOS.

Les contrôleurs militaires n'ont montré aucune préférence entre les FLOS. Ils ont considéré que pour opérer en toute sécurité des avions OAT dans un environnement RVSM, il serait nécessaire de pouvoir faire de la coordination directe avec les contrôleurs civils et d'avoir un système radar qui permettrait d'avoir des informations sur le choix des niveaux de vols du trafic civil.

### **2. De comparer la charge de travail du contrôleur et le volume de trafic des secteurs entre les trafics RVSM de base et deux échantillons de trafics de plus fort volume avec le FLOS « Double Alternate ». (Suite aux résultats obtenu dans l'objectif 1, le « Single » FLOS a été aussi étudié dans cet objectif).**

Il n'y avait aucune différence significative en terme de charge de travail du contrôleur entre le « Single » et le « Double » FLOS quelque soit le volume de trafic. La présence d'avions non-MASPS a accru la charge de travail des contrôleurs en comparaison avec un environnement totalement MASPS. Il y avait peu de différence en terme de charge de travail du contrôleur quand on a comparé CVSM avec un trafic RVSM avec 3% d'avions non-MASPS à volume de trafic égal.

Il y avait une diminution de la charge de travail du contrôleur dans les exercices RVSM sans avion non-MASPS pour un même volume de trafic.

Les trafics RVSM à +55% (0% non-MASPS) ont montré une charge de travail moyenne similaire aux trafics CVSM à +35%. Cela semble indiquer une augmentation de 20% en termes de volume de trafic mais il faut savoir que ceci a été obtenu qu'avec trois répétitions de l'échantillon de trafic, que les exercices +55% ont été joués durant la troisième semaine de simulation lorsque les contrôleurs étaient plus habitués aux trafics. Il est donc recommandé de valider ces résultats par une étude plus approfondie.

Les échantillons de trafic avec des niveaux de trafic augmentés ont généré une occupation importante de la radio. Il y avait une réduction notable des ordres donnés aux pilotes avec l'utilisation de RVSM, mais toujours aucune différence entre le « Single » et le « Double » FLOS. Il y avait une réduction significative du nombre de cap utilisés dans les exercices RVSM par rapport à CVSM (Cette réduction était encore plus notable en l'absence de trafic non-MASPS).



3. **De valider les procédures ATC générales établies par le sous-groupe « ATM Procedures Development » (y compris les procédures ATC d'intégration des avions d'Etat Non-MASPS) nécessaires à l'implémentation de RVSM avec le FLOS « Double Alternate ». (Suite aux résultats obtenu dans l'objectif 1, le « Single » FLOS a été aussi étudié dans cet objectif).**

### **Non-MASPS**

L'intégration des avions non-MASPS dans l'espace RVSM a causé beaucoup de problèmes. En particulier, ils ont réduit la sécurité et réduit les bénéfices de RVSM. La majorité du trafic non-MASPS a reçu soit des « vecteurs radar » soit un changement de niveau et le service des avions MASPS en était affecté.

Les contrôleurs ont utilisé 3 méthodes destinées à les aider à identifier les avions non-MASPS.

**Étiquette Radar :** Tous les contrôleurs utilisaient un écran Sony couleur. L'utilisation d'une étiquette radar verte pour identifier le trafic non-MASPS s'est révélée très efficace et tous les contrôleurs ont considéré que cela était nécessaire.

**Flight Strip :** Tous les contrôleurs ont considéré l'ajout des mots « Non-RVSM » sur le « strip » nécessaire, et beaucoup ont utilisé des « Porte strips » de couleurs différentes comme système mnémotechnique supplémentaire.

**Phraséologie :** Les contrôleurs ont considéré que la phraséologie R/T proposée était excessive et prenait trop de temps. Il a été convenu de modifier les procédures pour la simulation et tous les contrôleurs ont considéré que la phrase « Non-RVSM », utilisée au premier contact avec le secteur, était suffisante pour indiquer la certification de l'avion. La plupart des contrôleurs ont considéré qu'il n'était pas nécessaire d'utiliser cette phrase à chaque demande de changement de niveau.

4. **De valider les procédures ATC concernant les situations de contingences.**

Le passage de RVSM à CVSM puis RVSM n'a généré que peu de commentaires. Lorsqu'il n'y avait pas de niveau disponible les contrôleurs ont donné des caps pour amener les avions dans l'espace adjacent (ex: les zones militaires). La majorité des avions qui étaient dans l'impossibilité de se conformer à RVSM lors d'une défaillance technique a été descendue sans problème en dessous du niveau 290 comme recommandé. Les contrôleurs ont eu le sentiment qu'il serait nécessaire de pouvoir changer la couleur de l'étiquette radar d'un avion devenant non-MASPS suite à une défaillance technique.

5. **De déterminer l'impact opérationnel d'une nouvelle sectorisation verticale au niveau 345 des secteurs UE et UH de REIMS avec le FLOS « Double Alternate ».**

La charge de travail globale a été réduite par la coupure du secteur au niveau 345; cependant, à cause de l'absence de procédures préalables définies, il y a eu une augmentation de la coordination entre les secteurs supérieurs et inférieurs. Certains contrôleurs ont trouvé que la coupure du secteur à ce niveau affectait les procédures utilisées pour le trafic arrivant sur Paris.



### RECOMMANDATIONS

- La décision du choix du FLOS à utiliser dans l'espace ECAC doit être prise aussitôt que possible pour permettre le début de l'implémentation de RVSM. Au même moment un FLAS doit être évalué pour permettre un meilleur écoulement du trafic en Europe, particulièrement au points de croisement les plus importants.
- La simulation a identifié que les trafics non-MASPS GAT augmentaient sensiblement la charge de travail des contrôleurs. Il est toutefois recommandé que le nombre d'avions non-MASPS GAT soit limité à l'intérieur d'un espace RVSM. De nouvelles études devraient être conduites utilisant un plus petit nombre de non-MASPS GAT (1% ou 2%) pour confirmer les effets sur la charge de travail des contrôleurs et sur la sécurité.
- L'effet des perturbations Vortex dues au sillage des avions dans un environnement RVSM doit être analysé.
- La simulation a prouvé que de nouvelles phraséologies radio, étiquettes radar en couleur et indications spécifiques sur les strips ont aidé le contrôleur à identifier les trafics non-MASPS. Par conséquent dans l'intérêt de la sécurité, il est recommandé que toutes ces procédures soient introduites pour les trafics non-MASPS évoluant à l'intérieur de l'espace RVSM.
- Les procédures de contingences doivent être simulées quand un FLOS aura été choisi et selon des scénarios basés sur des situations vraisemblables.





## **ANNEX A**

### **MAPS OF SIMULATION AIRSPACE**



## **ANNEX B**

### **SIMULATION PARTICIPANTS**



# S08 PARTICIPANTS

## **EUROCONTROL - Experimental Centre**

Roger LANE	Project Manager
Hugh O'CONNOR	Deputy Project Manager
Jose SEIXO	Simulation Technical Co-ordinator
Marie Christine LEDUC	Data Preparation Expert
Robin DERANSY	Analyst
Peter SLINGERLAND	Operations room Supervisor
Diena SEEGER	FAA Observer
Martine PARVAIS	Administration
Laurent GUICHARD	Multi-Aircraft Cockpit Simulator Project Manager

## **EUROCONTROL - Headquarters**

Mark STONER	DED/4
-------------	-------

## **SWISSCONTROL - Geneva ATCC**

Kaspar SENN	Supervisor
Pierre BÉGUIN	
Sophie BILLAUD	
Eric JEMELIN	
Alain GABERELL	
Bertrand IMOBERSTEG	

## **SWISSCONTROL - Zurich ATCC**

Pietro SANGALETTI

### **Team 1**

Peter WINIGER  
Ester VON BURG  
Andreas ZURBUCHEN  
Willy MÜLLER

### **Team 2**

Roland NUSSBAUMER  
Karin NUSSBAUMER  
Sheung NG  
Nicole SCHWAB

## **DFS - Karlsruhe ATCC**

Burghard HORN	Supervisor
Klaus LIENEN	
Heinz STEHR	
Gerd LEIPERT	
Markus BADER	
Rudiger SCHEFFLER	Solligen sector assistant
Bernd LILL	Feed Controller from Frankfurt ATCC
Anton SCHREINER	Feed Controller from Frankfurt ATCC

## **CRNA - Est Reims ATCC**

Daniel MAZE	Supervisor
Michel ROCCA	Supervisor
Philippe LATROUITE	Supervisor
Ludovic BOULANGER	
Franck GITTINGER	
Oliver GERBIER	
Xavier GODICHAUD	
Pascal BOURGEOIS	
Serge RIBBENS	
Jean Jacques SALSEDO	

## **FRENCH MILITARY - Lyon CDC**

Guy DHAINE	Supervisor
Thierry RAFFIER	
Marc LEONARD	
Isabelle DELAGOUTTE	
Alain GUICHARD	

**ANNEX C**

**OPERATIONS ROOM LAYOUTS**





# ORGANISATION 1

## OPERATIONS ROOM

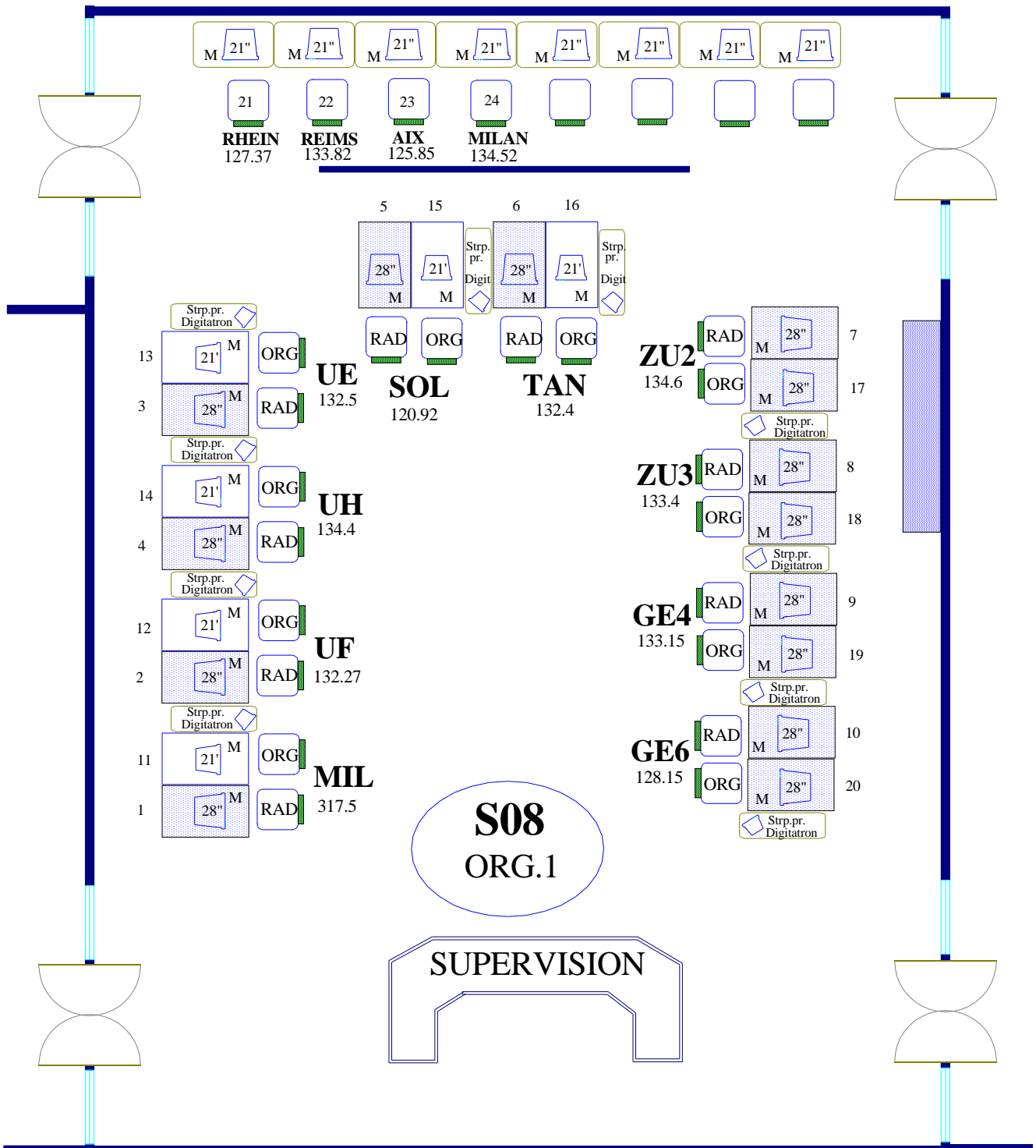

# ORGANISATION 2

## OPERATIONS ROOM

