

# EQUALISATION OF TIME VARIANT MULTIPATH CHANNELS USING AMPLITUDE BANDED TECHNIQUES

*Tetsuya Shimamura*

Department of Information  
and Computer Sciences  
Saitama University  
Urawa 338, Japan

*Colin F.N. Cowan*

Department of Electrical and  
Electronic Engineering  
Queen's University  
Belfast BT9 5AH, UK

## ABSTRACT

For the purpose of equalisation of rapidly time variant multipath channels, the RLS algorithm might provide better performance than the LMS algorithm. However, the RLS algorithm requires complicated operation to adapt the equaliser coefficients. In this paper, we derive a novel adaptive algorithm, amplitude banded LMS (ABLMS), and develop it as the adaptation procedure for a linear transversal equaliser (LTE) and a decision feedback equaliser (DFE). Computer simulations demonstrate that with small increase of computational complexity, the ABLMS equalisers provide a significant improvement related to the conventional LMS DFE as well as LMS LTE.

## 1. INTRODUCTION

Data transmission over a number of communications channels is restricted by the nonideal characteristics of the channels, such as rapid time variation, severe fading as well as bandwidth constraints. This is typical on high-frequency (HF) channels and mobile radio channels. Adaptive equalisation techniques are used to achieve high speed digital communications. However, rapid time variation of such channels often afflicts the adaptive equaliser, and as a result impairs the efficiency of communications. To obtain an acceptable error rate performance, one is obliged to rely on a complicated adaptive technique. This is, however, not practically beneficial. Therefore, it is desired to develop an efficient adaptive algorithm working robustly in time variant environments.

A linear transversal equaliser (LTE) and a decision feedback equaliser (DFE) are commonly used for communications channel equalisation. The DFE has an inherent problem associated with the error propagation, but often provides better performance than the LTE. In [1][2], the use of the DFE has been proposed

on multipath channels involving time variation.

This paper proposes a novel technique for adaptive equalisers, amplitude banded technique, to cope with time variant multipath channels, and sets out to implement a nonlinear adaptation process on a coefficient matrix. Amplitude information of the received sequence is deployed for the purpose of switching the coefficients to be updated. A novel adaptation algorithm, amplitude banded least mean square (ABLMS) algorithm, is derived and developed as the adaptation procedure for both the LTE and the DFE.

The channel is assumed to be a discrete-time finite impulse response channel corrupted by additive noise. Thus if  $u_k$  is the transmitted sequence, the output of the channel is a noise-corrupted sequence  $x_k$  given by

$$x_k = \sum_{i=0}^{L-1} h_i(k)u_{k-i} + n_k \quad (1)$$

where  $h_0(k), h_1(k), \dots, h_{L-1}(k)$  is the channel impulse response and  $n_k$  is a Gaussian white noise uncorrelated with  $u_k$ .

## 2. LMS ALGORITHM

For the standard LMS algorithm (normalised version), the tap coefficient vector  $\mathbf{c}(k)$  is updated by the following equation:

$$\mathbf{c}(k+1) = \mathbf{c}(k) + \frac{\mu}{\beta + \mathbf{x}(k)^T \mathbf{x}(k)} \mathbf{x}(k) \epsilon_k \quad (2)$$

where  $\mathbf{x}(k)$  is the input vector,  $\epsilon_k$  is the output error sequence, and  $\mu$  and  $\beta$  are constant parameters to control the convergence. When  $\mathbf{c}(k)$  and  $\mathbf{x}(k)$  are given by  $\mathbf{c}(k) = (c_0(k), c_1(k), \dots, c_{M-1}(k))^T$  and  $\mathbf{x}(k) = (x_k, x_{k-1}, \dots, x_{k-M+1})^T$ , respectively, Equation (2) provides the adaptation procedure for an  $M$  length LTE. On the other hand, if  $\mathbf{c}(k)$  and  $\mathbf{x}(k)$  are replaced by

$\mathbf{c}'(k) = (c_0(k), c_1(k), \dots, c_{M_f+M_b-1}(k))^T$  and  $\mathbf{x}'(k) = (x_k, x_{k-1}, \dots, x_{k-M_f+1}, \hat{u}_{k-d-1}, \hat{u}_{k-d-2}, \dots, \hat{u}_{k-d-M_b})^T$ , respectively, Equation(2) becomes the adaptation procedure for an  $M_f + M_b$  length DFE, where  $\hat{u}_{k-d}$  is an estimate of the transmitted sequence delayed by  $d$  and  $M_f$  and  $M_b$  are the length of the feedforward and feedback filters, respectively.

### 3. ABLMS ALGORITHM

For the amplitude banded algorithm to be proposed here, in the case of an LTE, a  $Q$  by  $M$  coefficient matrix  $\mathbf{C}_a(k)$  is prepared, elements of which are given by  $c_{ij}(k), i = 1, 2, \dots, Q, j = 1, 2, \dots, M$ . Then, among the  $Q$  by  $M$  elements, only  $M$  elements,  $c_{q(j)j}(k), j = 1, 2, \dots, M$ , are selected and a coefficient vector is set as  $\mathbf{c}_a(k) = (c_{q(1)1}(k), c_{q(2)2}(k), \dots, c_{q(M)M}(k))^T$  where  $q(j)$  is an integer and determined based on the amplitude level of each element  $x_{k-j+1}$  of the input vector  $\mathbf{x}(k)$  for  $j = 1, 2, \dots, M$  as follows:

- if  $A_{max} \geq |x_{k-j+1}| \geq A_{max}(1-1/Q)$ , then  $q(j) = 1$ .
- if  $A_{max}(1-1/Q) > |x_{k-j+1}| \geq A_{max}(1-2/Q)$ , then  $q(j) = 2$ .
- if  $A_{max}(1-2/Q) > |x_{k-j+1}| \geq A_{max}(1-3/Q)$ , then  $q(j) = 3$ .
- .
- .
- if  $A_{max}/Q > |x_{k-j+1}| \geq 0$ , then  $q(j) = Q$ .

The  $A_{max}$  denotes the maximum amplitude of the received sequence and  $Q$  corresponds to a division number to classify the level of the amplitude of the received sequence. The elements of  $\mathbf{c}_a(k)$  are switched at each time  $k$  and then updated. The output of this filter is obtained by the convolution between  $\mathbf{c}_a(k)$  and  $\mathbf{x}(k)$ . Thus the coefficient vector is also updated by the LMS algorithm (2) where  $\mathbf{c}(k)$  is replaced by  $\mathbf{c}_a(k)$ . This algorithm provides the ABLMS algorithm for an  $M$  length LTE. If  $\mathbf{c}_a(k)$  and  $\mathbf{x}(k)$  are given by  $\mathbf{c}_a'(k) = (c_{q(1)1}(k), c_{q(2)2}(k), \dots, c_{q(M_f+M_b)M_f+M_b}(k))^T$  and  $\mathbf{x}'(k)$ , respectively, this algorithm becomes the ABLMS algorithm for an  $M_f + M_b$  length DFE.

The basic idea of the amplitude banded technique is that if some degree of redundancy in a coefficient vector is permitted and if the coefficients to be updated are selected based on information associated with the channel impulse response, the adaptation may work to effectively track the time variation the channel involves. The ABLMS algorithm deploys the amplitude of the

received sequence as the information to select the coefficients to be updated.

The ABLMS algorithm provides good performance by being aided by the standard LMS algorithm in a parallel form. Figure 1 illustrates the whole configuration of the ABLMS algorithm based LTE. For its DFE version, the ABLMS DFE is constructed in parallel with the LMS DFE.

### 4. SIMULATION RESULTS

Two channel models are used in our simulations. One is that the transfer function of which is given by

$$\text{Channel 1 : } H_1(z) = 1 + \sin\left(\frac{2\pi}{T}k\right)z^{-1} \quad (3)$$

where  $T$  is the period to control the rate of time variation of the channel. The other is given by

$$\text{Channel 2 : } H_2(z) = h_0(k) + h_1(k)z^{-1} + h_2(k)z^{-2} \quad (4)$$

where the time variant coefficients,  $h_0(k)$ ,  $h_1(k)$  and  $h_2(k)$  are generated by passing a Gaussian white noise through a second order Butterworth filter which is designed with sampling rate of 2400 sample/s. For this channel model, the channel fade rate can be quoted as the 3 dB bandwidth for the Markov process. The input sequence of both channels is a pseudo-random sequence with values of +1 or -1. (Channel 2 corresponds to an HF channel model  $H_3(z)$  used in [2].)

In a time variant environment, the ABLMS algorithm provides faster tracking than the corresponding LMS algorithm. Figure 2 shows the convergence of the LMS LTE and the ABLMS LTE for  $M = 6$ ,  $d = 0$ ,  $\mu = 0.3$  and  $\beta = 0.05$  on channel 1 with the value of  $T = 3000$ . The additive noise is -50 dB. The division number for the ABLMS algorithm is set to  $Q = 6$ . In this channel model, the channel becomes unequalisable at  $k = 750$  and  $k = 2250$ , and becomes undistorted at  $k = 1500$  and  $k = 3000$ . Figure 2 shows that especially from  $k = 750$  to  $k = 1500$  and from  $k = 2250$  to  $k = 3000$  the tracking speed of the ABLMS algorithm is faster than that of the LMS algorithm, while the initial convergence speed of both algorithms is almost the same. Although this channel model is not realistic, it is sufficient to show the tracking superiority of the ABLMS algorithm related to the LMS algorithm.

Figure 3 shows the bit error rate(BER) performance of the LMS LTE, LMS DFE, ABLMS LTE and ABLMS DFE against additive noise on channel 2 with a fade rate of 2 Hz. The equalisers have the filter length  $M = 9$  for LTEs and  $M_f = 5$  and  $M_b = 2$  for DFEs, both of which provide the best performance for the filter structure, respectively, as shown in Figure 4. In Figure

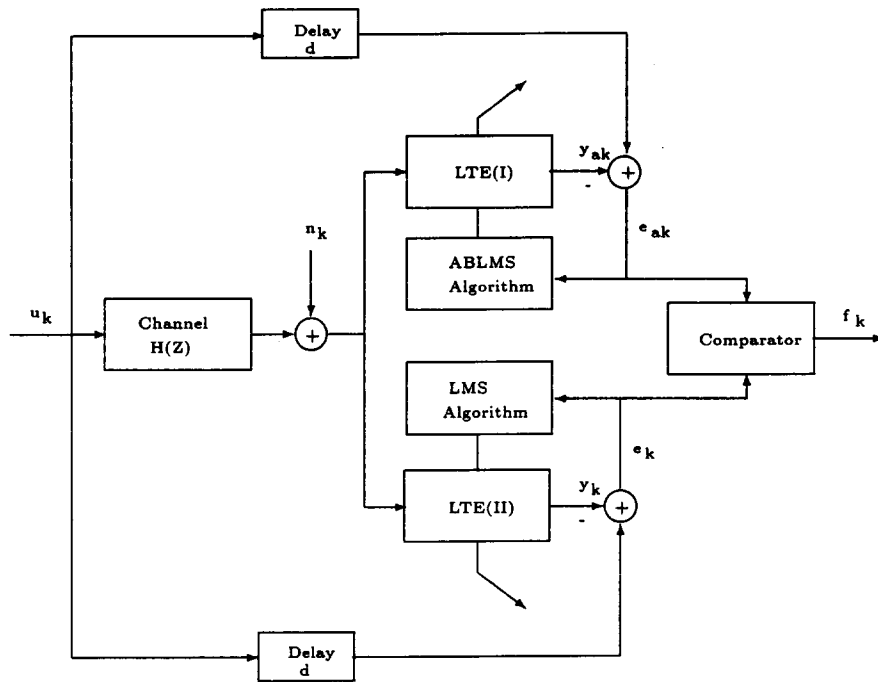

Figure 1: Configuration of the ABLMS LTE in parallel with the LMS LTE. The comparator provides  $f_k = e_{ak}$  if  $(e_{ak})^2 \leq (e_k)^2$  and  $f_k = e_k$  otherwise. The output of this equaliser is  $y_{ak}$  when  $f_k = e_{ak}$ , and  $y_k$  when  $f_k = e_k$ .

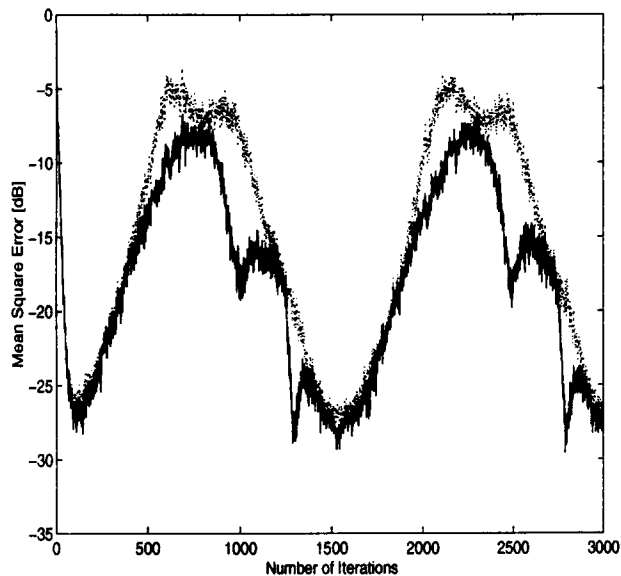

Figure 2: Convergence of the LMS LTE(dotted line) and ABLMS LTE(solid line).

3, the constant parameters and the delay are commonly for both filter structures set to  $\mu = 0.5$ ,  $\beta = 0.05$  and  $d = 4$ , respectively. The division number  $Q$  of the ABLMS algorithm is 6. Figure 3 clearly shows that the amplitude banded equalisers provides performance improvement. Also, Figure 3 shows that based on the structure of the LTE rather than the DFE, the ABLMS algorithm provides better performance.

Carefully looking at Figure 4, we notice that the DFE is more sensitive to the equaliser order than the LTE. This is because for a DFE, the effect of noise enhancement by the feedforward filter is enhanced by the feedback filter as the filter order is increased. This undesirable feature visualised for the DFE on time variant channels may motivate the use of the LTE on time variant channels in favour of the ABLMS algorithm, because the difference between the optimal BERs achieved by the LTE and the DFE is slight, as shown in Figure 4.

Figure 5 is an illustration of the BER performance against channel fade rates on channel 2 with a signal-to-noise ratio of 20 dB where the LMS LTE, LMS DFE, ABLMS LTE and ABLMS DFE are compared again. The condition of the all equalisers is the same as that in Figure 3. Figure 5 shows that especially in the range of fade rates 0.5 to 2 Hz, which are often encountered

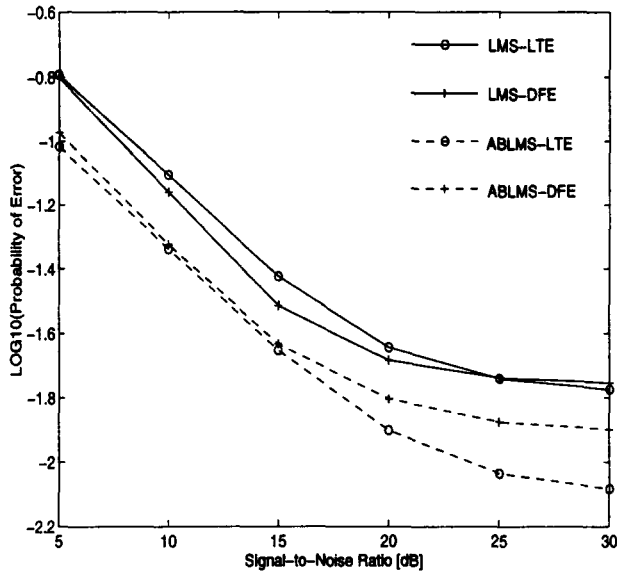

Figure 3: Bit error rate performance against additive noise on channel 2.

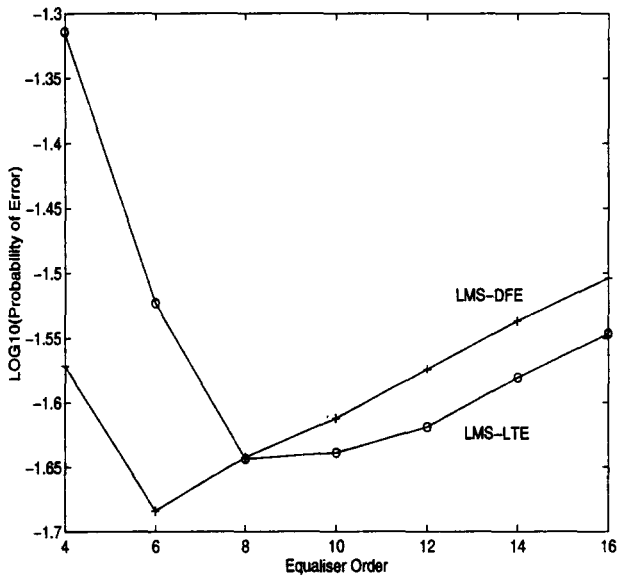

Figure 4: Equaliser order dependency for the LMS LTE and LMS DFE on channel 2 with a fade rate of 2 Hz and a signal-to-noise ratio of 20 dB. The equaliser order corresponds to  $M - 1$  for the LTE and  $M_f + M_b - 1$  for the DFE. For the LTE, the delay is set to  $(M - 1)/2$ . For the DFE,  $M_b$  is fixed on  $M_b = 2$ .

in practical situations, the ABLMS LTE significantly outperforms the ABLMS DFE as well as the LMS DFE. Also, it should be here noted that the ABLMS LTE has the sufficient potential to achieve acceptable BER less than  $10^{-2}$ .

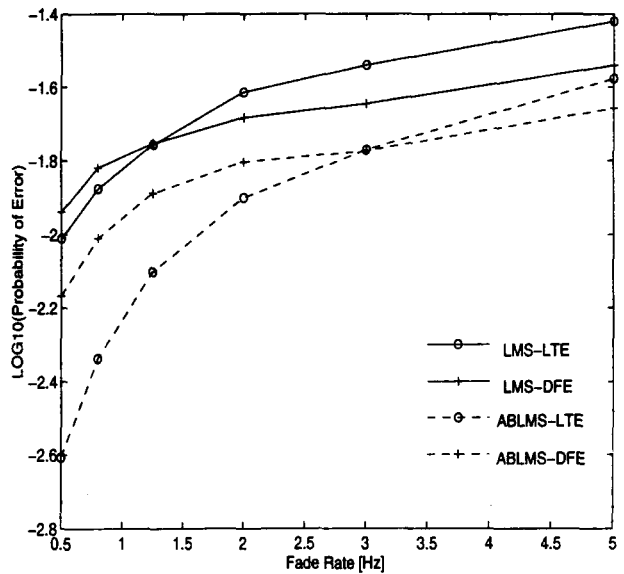

Figure 5: Bit error rate performance against channel fade rates on channel 2.

## 5. COMPUTATIONAL COMPLEXITY

Although computational complexity of the ABLMS itself is equivalent to that of the LMS algorithm, the ABLMS algorithm needs the aid of the LMS algorithm as shown in Figure 1. Thus, the whole computational complexity required to implement the ABLMS LTE is twofold that required to do the LMS LTE, but this is much less than that required to do the recursive least squares algorithm based LTE or DFE.

## 6. REFERENCES

- [1] P.Monsen : Fading channel communications, IEEE Communications Magazine, pp.16-25, Jan. 1980.
- [2] F.Ling and J.G.Proakis : Adaptive lattice decision-feedback equalisers - Their performance and application to time-variant multipath channels, IEEE Trans. Vol.COM-33, No.4, pp.348-356, April 1985.